

Kaiser

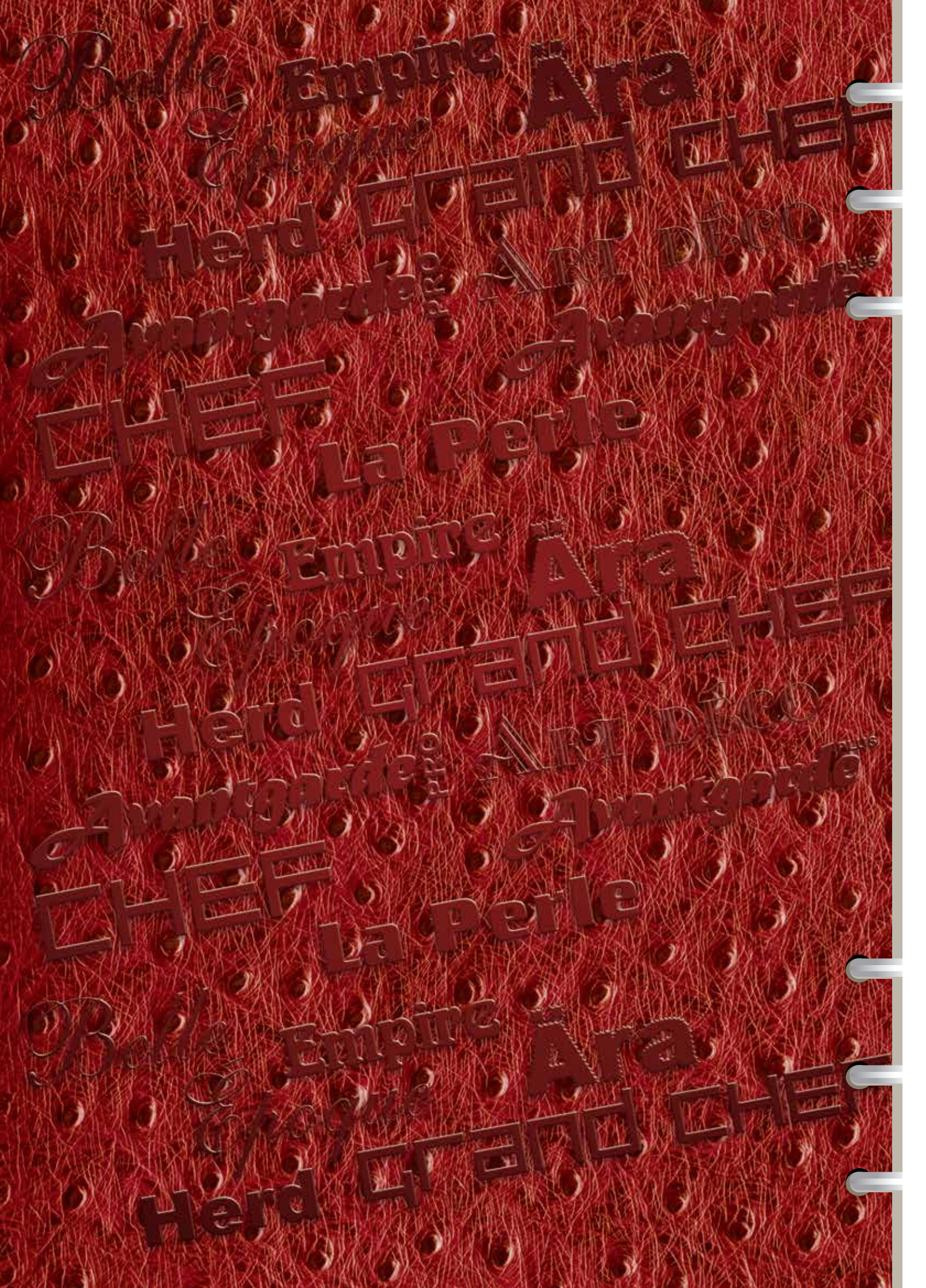

**FIRST CLASS
HOME APPLIANCES**



CONTENTS

	page
1. Ovens and built-in cookers	7
1.1 Electric ovens	8
1.2 Gas ovens	23
2. Hobs	25
2.1 Glass ceramic hobs	26
2.1.1 Induction glass ceramic hobs	29
2.1.2 Hi-light + induction glass ceramic hobs	36
2.1.3 Hi-light glass ceramic hobs	36
2.2 Gas hobs	40
2.2.1 Gas hobs with glass top	41
2.2.2 Gas hobs with stainless steel top	47
2.2.3 Gas hobs with enameled top	51
3. Cookers	53
3.1 Electric cookers with induction cooktop	54
3.2 Electric cookers with gas cooktop	57
3.3 Gas cookers	59
4. Cooker hoods	61
4.1 Wall-mounted cooker hoods	63
4.2 Island cooker hoods	73
4.3 Built-in cooker hoods	77
5. Microwaves	81
5.1 Built-in microwave ovens	83
5.2 Free-standing microwave ovens	84
6. Refrigerators	85
6.1 Fridge freezer combinations	88
6.2 Built-in combination	89
6.3 Side-by-side combination	90
6.4 Wine coolers	91
7. Dishwashers	93
8. Installation diagrams	103

Kaiser

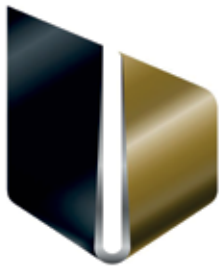

german
brand
award
17
winner

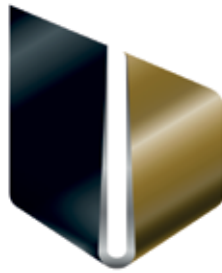

german
brand
award
18
winner



GERMAN
DESIGN
AWARD
NOMINEE
2020

Dear customers,

Kaiser is greeting you on the pages of our catalog!
Welcome to the world of modern home appliances!

The fundamental idea behind developing of the technology ***Kaiser*** — to make the power of the modern and beautiful innovation work for the benefit of modern and beautiful people.

This idea constantly motivates our engineers and designers to improve our technology to comply with all requirements of our customers and to fulfil the modern lifestyle.

Owing to use of the latest know-how the technology ***Kaiser*** has a wide range of applications, of the automatic functions and the ease of use and maintenance.

Kaiser

Our domestic appliances are distinguished by their unique design as in classical as well as in innovative shape.

We make become reality things, which were previously considered as the science fiction: self-cleaning dishwasher, ultrathin Induction- hobs whose surfaces are so safe, that the burning is excluded, multifunctional ovens, which can be easy cleaned even after intensive use.

Our slogan — **Power in action.**

The resources invested in design and technical performance pursue the target - to convey our customers the **Power in action** of our technology.

We care about the well-being of our customers.

Faithfully yours

Kaiser

**OLAN-Haushaltsgeräte
Berlin Germany**





Built-in ovens



ELECTRIC OVENS

Kaiser has developed a model range of ovens with the energy efficiency class A.

However our ovens are characterized not only by a low energy consumption, but also by very user-friendly operation and simple maintenance. The all aspects of comfort have been considered to make our customers feel satisfaction and pleasure in using of our technology. Our multifunctional ovens offer an exceptional variety of ways that ensure the optimal preparation of your favorite dishes. Electronic **Logic Control, Nickel FREE Easy clean- enamel, catalytic clean system, Telescope system, rotisserie** and many other features will bring you a lot of fun. The special system of external cooling enables you to install the ovens even in small kitchens, without causing any damage.



Electronic controls

The electronic system **Logic control** and **Intelligent system** take control Intelligent system of the cooking process, while you are reading your favourite book or watching a favourite show.

There is a recommended temperature for each cooking mode, but you can always change the temperature to your needs.



Telescope system

Many of our ovens are equipped with the **Telescope system**. This system ensures the gentle removal of the trays, resilient up to 15 kg. You can take out the trays also during the cooking.

According to reports of our customers is the **Telescope system** very convenient and easy.

If your oven is not equipped with the system, you can order it separately .

Electric rotisserie

The using of the electric rotisserie make your favorite dishes taste delicious.

Depending on your culinary imagination you can use the rotisserie together with the infrared grill. This combination will lead to the superior cooking results.

The infrared grill is ideal if you like to cook fish, steaks or toasts in the oven. If you like to eat crispy dishes, you can fry with gap open oven door or using the fan.



Multifunction



The numerous functions of the ovens **Kaiser** allow the quick and delicious preparation of your favorite dishes. The ovens **F12 Biturbo** and **F14 Biturbo** are equipped with the all modern features.

With these functions, you can adjust the oven individually, quickly and accurately.

ELECTRIC OVENS



Comfortable and pleasant control

The most ovens *Kaiser* are equipped with an ergonomic touch-screen control, from simple three-button touch control to the electronic **Full touch control**.

The cleaning of the surfaces of the ovens with full sensor operation is very simple and fast, because there are no convex buttons.

The ovens *Kaiser* are equipped with comfortable, ergonomic and elegant door handles made of solid metal.

Many models of the ovens are equipped with recessed **PUSH** knobs. In combination with the touch screen control it offers the high serviceability.

Easy clean – enamel Nickel FREE

The interior of many ovens is coated with the Easy Clean enamel **Nickel FREE** of *Kaiser*

This enamel has the following features:

- Durable coating with long service life
- Easy care. Similar to pyrolytic cleaning, but at lower Temperatures
- Suitable for nickel allergy sufferers
- Hygienic
- Environmental Friendly
- Gloss, smoothness, color, weather and temperature resistance

This coating guarantees a healthy eating and easy cleaning of your oven.



Pyrolytic and catalytic cleaning

A permanent self-cleaning through **catalysis** cleans the hard to reach areas of the ovens as ceiling and rear wall: the fat and sauces splashes can not be removed easier and more convenient. All of the fat substances will be catalyzed, evaporated, and eliminated at the temperature above 200 °C.

The interior of the oven with the **pyrolysis** function will be heated to the temperature of 400 °C. All organics will be decomposed by the heat and their molecules will be destroyed.



Recipes table

On the inside of the oven door you will find the recipe table. It helps you to find the required function and time to cooking of your favorite dish.

Cold front of the oven

The doors of the oven *Kaiser* have a special design. They are equipped with the double or triple glazing. This ensures good insulation, so that the front of the oven always stay cool.

The new generation of the model range



La Perle

**with multilingual
Touch Screen TFT display**



The ovens with microwave, steam ovens, coffee machines and cooker hoods are also represented in the new generation of the built-in appliances .

La Perle

If you want to delight your guests, the home appliances of this model range are the right choice for you!

La Perle

La Perle



ELECTRIC OVEN with pyrolytic cleaning, steam function **La Perle** and multilingual TFT touch screen display

Multi 23



EH 6311 Pyrolyse

Full touch **Teleskop** **Turbo heat** **INOX Anti touch**
INTELLIGENT SYSTEM

Design

- Product line **La Perle**
- Black glass / INOX frame
- Elegant door handle INOX
- Panoramic inner glass with recipe table

Features

- Tangential circulation system
- Shelf support chromed rails
- Telescopic extension system **Teleskop** – 1 level, optional up to 3 levels
- 5 Rack levels
- Automatic lighting switch on by door opening

Equipment

- 1 enamelled baking tray
- 1 enamelled baking pan
- 1 multifunction roast shelf
- 1 steam pipe
- 1 chromed handle for Trays
- 1 food probe

Control

- Electronic programmer **Intelligent System**
- Electronic full sensor control with programmer **Full Touch**
- Multilingual **TFT** display
- Child lock

Comfort

- Multifunctional electric oven **Multi 23**
- 10 heating modes**
- 13 special functions** incl. **Steam function**
- Quick heating for any function **Turbo heat**
- Quick high temperature **Pyrolytic cleaning**
- Cold front – **4 glasses** oven door
- Special thermo-reflective glass **THERMO-REFLECTIVE**

Technical specifications

Energy efficiency class	A
Oven capacity, l	77
Grill power, kW	1,2
Double grill power, kW	2,2
Hot air power, kW	2,3
Bottom heating element, kW	1,1
Upper heating element, kW	1,0
Lighting, kW	0,025
Total power, kW	3,5
Net weight, kg	40,5
Gross weight, kg	44,5

Dimensions (H × W × D, cm)

Oven dimensions	58,9 × 59,4 × 56,8
Niche Dimensions set	57,5 × 56,5 × 54,3
Dimensions in packaging	66,0 × 64,7 × 68,0

Multi 22



EH 6310

Full touch **Teleskop** **Turbo heat** **INOX Anti touch**
INTELLIGENT SYSTEM

Design

- Product line **La Perle**
- Black glass / INOX frame
- Elegant door handle INOX
- Panoramic inner glass with recipe table

Features

- Tangential circulation system
- Shelf support chromed rails
- Telescopic extension system **Teleskop** – 1 level, optional up to 3 levels
- 5 Rack levels
- Automatic lighting switch on by door opening

Equipment

- 1 enamelled baking tray
- 1 enamelled baking pan
- 1 multifunction roast shelf
- 1 chromed handle for Trays
- 1 food probe

Control

- Electronic programmer **Intelligent System**
- Electronic full sensor control with programmer **Full Touch**
- Multilingual **TFT** display
- Child lock

Comfort

- Multifunctional electric oven **Multi 22**
- 10 heating modes**
- 12 special functions**
- Quick heating for any function **Turbo heat**
- Cold front — **4 glasses** oven door
- Special thermo-reflective glass **THERMO-REFLECTIVE**

Technical specifications

Energy efficiency class	A
Oven capacity, l	77
Grill power, kW	1,2
Double grill power, kW	2,2
Hot air power, kW	2,3
Bottom heating element, kW	1,1
Upper heating element, kW	1,0
Lighting, kW	0,025
Total power, kW	3,5
Net weight, kg	40,5
Gross weight, kg	44,5

Dimensions (H × W × D, cm)

Oven dimensions	58,9 × 59,4 × 56,8
Niche Dimensions set	57,5 × 56,5 × 54,3
Dimensions in packaging	66,0 × 64,7 × 68,0

La Perle

Compact microwave oven with grill, convection, TFT display, Full touch control



Full touch Teleskop INOX Anti touch INTELLIGENT SYSTEM

Design

- Product line La Perle
- Black glass / INOX frame
- Elegant door handle INOX

Features

- Tangential circulation system
- Stainless steel interior

Multi 16 Prog x 8

Equipment

- 1 Chromed multifunction roast shelf
- 1 Turnable plate Ø 32 cm

Control

- Electronic programmer **Intelligent System**
- Electronic full sensor control with programmer **Full Touch**
- Multilingual **TFT** display
- Child look

Comfort

- Microwave oven **F16** with infrared grill and convection
- Preset recipes**, include meat, fish, vegetable cooking, pizza etc.
- Microwave, Grill, Convection, combinations of them
- Automatic defrost, heating, and cooking of various types of products according time and weight

Technical specifications

- Usable volume, l 38
- Microwave power, kW 1,0
- Grill power, kW 1,65
- Convection power, kW 1,5
- Net weight, kg 35,0
- Gross weight, kg 38,5

Dimensions H x W x D (cm)

- Oven dimensions 45,5 x 59,4 x 48,6
- Niche dimensions 45,2 x 56,5 x 60,0
- Dimensions in packaging 52,5 x 67,5 x 66,6

Fit into a standard built-in niche with warming drawer **EH 6314 GW**

Compact oven with steamer function, TFT display, Full touch control



Full touch Teleskop INOX Anti touch INTELLIGENT SYSTEM

Design

- Product line La Perle
- Black glass / INOX frame
- Elegant door handle INOX

Features

- Tangential circulation system
- Stainless steel interior
- Shelf support chromed rails
- 5 Rack Levels

Multi 19 Clean x 5 x 5 x 5

Equipment

- 1 chromed multifunction roast shelf
- 1 multifunction stainless steel tray
- 1 perforated stainless steel tray
- 1 water tank

Control

- Electronic programmer **Intelligent System**
- Electronic full sensor control with programmer **Full Touch**
- Multilingual **TFT** display
- Child look

Comfort

- Steam oven **F19** with infrared grill
- Preset recipes**, include meat, vegetables, seafood
- Steam cooking, Grill, combinations of them
- Automatic defrost, heating, and cooking of various types of products according time and weight

Technical specifications

- Usable volume, l 38
- Steamer power, kW 1,5
- Grill power, kW 1,7
- Net weight, kg 29,5
- Gross weight, kg 33,5

Dimensions H x W x D (cm)

- Oven dimensions 45,5 x 59,4 x 48,6
- Niche dimensions 45,2 x 56,5 x 60,0
- Dimensions in packaging 52,5 x 67,5 x 61,1

Fit into a standard built-in niche with warming drawer **EH 6314 GW**

La Perle

Compact coffeemaker with TFT display, Full touch control



EH 6318 KA

INTELLIGENT SYSTEM **INOX And touch** **Teleskop** **Full touch**

Design

- Product line **La Perle**
- Black glass / INOX frame

Features

- Telescopic extension rails for serve of the unit
- Coffee grind
- Steam generator
- Automatic stand by switch - Energy saving

Equipment

- Container for waste coffee
- Water tray

Control

- Electronic programmer **Intelligent System**
- Electronic full sensor control with programmer **Full Touch**
- Multilingual **TFT** display
- Child lock

Comfort

- Multifunctional coffee machine
- **Programs espresso, coffee, cappuccino, latte, steam**
- Water hardness setting
- Coffee statistics system
- Filters cleaning / changing informer
- Coffee / water lack informer

Multi 8



Technical specifications

- Water tank volume, l 1,8
- Preassure, bar 20
- Net weight, kg 21,5
- Gross weight, kg 28,0

Dimensions H x W x D (cm)

- Unit dimensions 44,9 x 59,4 x 47,1
- Niche dimensions 46,0 x 56,5 x 60,0
- Dimensions in packaging 54,5 x 65,5 x 56,5

Fit into a standard built-in niche with warming drawer **EH 6314 GW**

Warming drawer



EH 6314 GW

INOX And touch **Teleskop**

Design

- Product line **La Perle**
- Black glass / INOX frame

Features

- System **Teleskop**
- Shelve with non-slip mat for dishes, up to **25 kg**:
 - 6 tableware complete sets
 - 20 plates Ø 28 cm
 - 40 tea cups
 - 80 coffee cups etc.

Control

- Electronic control
- **LED** indication

Comfort

- Hot air system for heating of various tableware
- Infinitely variable temperature control, up to 60 °C
- Cold front

Technical specifications

- Interior height, mm 100
- Total power, kW 0,47
- Net weight, kg 16,5
- Gross weight, kg 18,0

Dimensions H x W x D (cm)

- Unit dimensions 14,5 x 59,4 x 59,0
- Niche dimensions 14,5 x 56,5 x 60,0
- Dimensions in packaging 21,0 x 65,4 x 65,7

Fit into a standard built-in niche with microwave oven **EH 6319**, steamer **EH 6312**, coffeemaker **EH 6318 KA**

Electric ovens with metal rotary knobs



EH 6337

Touch control INTELLIGENT SYSTEM Teleskop INOX Anti touch

Stainless steel with Anti touch-effect / black glass

Design

- Product line *Avantgarde*
- Elegant solid metal door handle
- Panoramic inner glass with recipe table

Features

- Tangential circulation system
- Shelf support chromed rails
- 5 Rack levels
- Telescopic extension system **Teleskop** – 2-fold used in every level, optional up to 3-fold

Equipment

- 2 enamelled trays with **Easy-clean** antiallergic enamel
- 1 multifunction chromed roast shelf
- 1 chromed handle for trays

Control

- Electronic sensor-controlled programmer **Intelligent System** with solid metal rotary knobs INOX
- Electronic sensor-controlled programmer **Touch control**
- Multifunction **LED**-display

Multi 11



Comfort

- **XXL** Multifunctional electric oven **Multi 11** with pyrolytic function
- **10 heating modes**
- **Pyrolytic clean function**
- **Easy-clean** antiallergic enamel
- Cold front – **4 Glasses**-oven door
- Special **THERMO-REFLECTIVE** glass

Technical specifications

- Energy efficiency **A**
- Gross capacity, L 79
- Net capacity according to EU standards, L 73
- Total power, kW 3,22
- Net weight, kg 43,3
- Gross weight, kg 47,8
- **Dimensions** H x W x D, (cm)
- Oven dimensions 59,4 x 59,4 x 55,6
- Niche dimensions 55,8 x 56,7 x 54,3
- Dimensions in packaging 64,4 x 66,0 x 66,5



EH 6338 S

Touch control INTELLIGENT SYSTEM Teleskop INOX Anti touch

Black glass

Design

- Produkt line *Avantgarde*
- Elegant solid metal door handle INOX
- Panoramic inner glass with recipe table

Features

- Tangential circulation system
- Shelf support chromed rails
- 5 Rack levels
- Telescopic extension system **Teleskop** – 2-fold used in every level, optional up to 3-fold



EH 6338 W

Touch control INTELLIGENT SYSTEM Teleskop INOX Anti touch

White glass

Equipment

- 2 enamelled trays with **Easy-clean** antiallergic enamel
- 1 multifunction chromed roast shelf
- 1 chromed handle for trays

Control

- Electronic sensor-controlled programmer **Intelligent System** with solid metal rotary knobs INOX
- Electronic sensor-controlled programmer **Touch control**
- Multifunction **LED**-display

Multi 11



Comfort

- **XXL** Multifunctional electric oven **Multi 11** with **pyrolytic** function
- **10 heating modes**
- **Pyrolytic clean function**
- Reinigungsfreundliche antiallergische **Easy-clean** antiallergic enamel
- Cold front – **4 Glasses**-oven door
- Special **THERMO-REFLECTIVE** glass

Technical specifications

- Energy efficiency **A**
- Gross capacity, L 79
- Net capacity according to EU standards, L 73
- Total power, kW 3,22
- Net weight, kg 43,3
- Gross weight, kg 47,8

Dimensions

- **Dimensions** H x W x D (cm)
- Oven dimensions 59,4 x 59,4 x 55,6
- Niche dimensions 55,8 x 56,7 x 54,3
- Dimensions in packaging 64,4 x 66,0 x 66,5

ELECTRIC OVENS

GRAND CHEF

Electric ovens with push-pull knobs

Multi 8

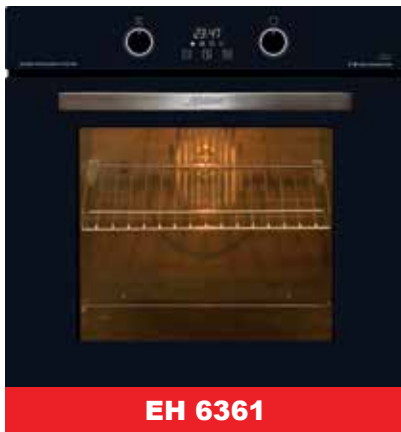

EH 6361

Touch control PUSH Teleskop INTELLIGENT SYSTEM

Black glass

Design

- Produkt line GRAND CHEF
- Elegant door handle black INOX
- Panoramic inner glass with recipe table

Features

- Tangential circulation system
- Turnable rotisserie with chromed frame and removable handle
- Shelf support chromed rails
- Telescopic extension system **Teleskop** – 1-fold used in every level, optional up to 3-fold
- 5 Rack levels

Equipment

- 2 enamelled trays with **Easy-clean** antiallergic enamel
- 1 multifunction chromed roast shelf
- 1 chromed handle for trays



EH 6361 G

Touch control PUSH Teleskop INTELLIGENT SYSTEM

Grey glass

Control

- Electronic sensor-controlled programmer **Intelligent System** with illuminated retractable knobs **Push Pull**
- Electronic sensor-controlled programmer **Touch control**
- Multifunction **LED**-display

Comfort

- **XXL** Multifunctional electric oven **Multi 8**
- **8 operating modes**
- **Catalytic self-cleaning**
- **Easy-clean** antiallergic enamel
- Removable door and inner glass
- Cold front – **3 Glasses**-oven door
- Special **THERMO-REFLECTIVE** glass

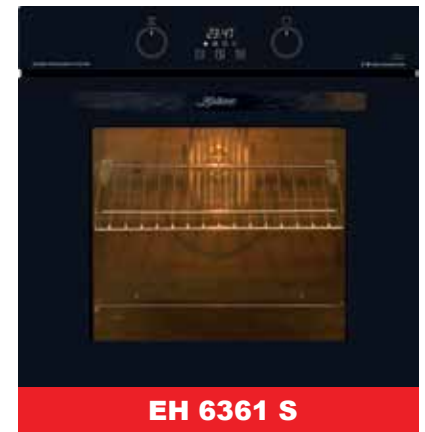

EH 6361 S

Touch control PUSH Teleskop INTELLIGENT SYSTEM

Black glass

Technical specifications

- Energy efficiency **A**
- Oven capacity, L 79
- Net capacity according to EU standards, L 73
- Total power, kW 2,56
- Net weight, kg 42,0
- Gross weight, kg 46,0

Dimensions H × W × D (cm)

- Oven dimensions 59,4 × 59,4 × 55,6
- Niche dimensions 55,8 × 56,7 × 54,3
- Dimensions in packaging 64,4 × 66,0 × 66,5

GRAND CHEF



ELECTRIC OVENS

Electric ovens with metal rotary knobs

GRAND CHEF

Multi 8



EH 6322

Touch control INTELLIGENT SYSTEM Teleskop INOX Anti touch

Stainless steel with Anti touch-effect/ black glass

Design

- Product line GRAND CHEF
- Elegant door handle INOX
- Panoramic inner glass with recipe table



EH 6324 Sp

Touch control INTELLIGENT SYSTEM Teleskop INOX Anti touch

Black mirror glass with bevels

Features

- Tangential circulation system
- Turnable rotisserie with chromed frame and removable handle
- Shelf support chromed rails
- Telescopic extension system **Teleskop** – 1-fold used in every level, optional up to 3-fold
- 5 Rack levels

Equipment

- 2 enamelled trays with **Easy-clean** antiallergic enamel
- 2 multifunction chromed roast shelf
- 1 chromed handle for trays

Control

- Electronic sensor-controlled programmer **Intelligent System** with metal rotary knobs
- Electronic sensor-controlled programmer **Touch control**
- Multifunction **LED**-display

Comfort

- **XXL** Multifunctional electric oven **Multi 8**
- **8 operating modes**
- **Catalytic self-cleaning**
- **Convection fan**
- **Easy-clean** antiallergic enamel
- Removable door and inner glass
- Cold front – **3 glasses** oven door
- Special **THERMO-REFLECTIVE** glass

Technical specifications

- | | |
|---|----------|
| • Energy efficiency | A |
| • Gross capacity, L | 79 |
| • Net capacity according to EU standards, L | 73 |
| • Total power, kW | 2,56 |
| • Net weight, kg | 42,0 |
| • Gross weight, kg | 46,0 |

Dimensions H × W × D (cm)

- | | |
|---------------------------|--------------------|
| • Oven dimensions | 59,4 × 59,4 × 55,6 |
| • Niche dimensions | 55,8 × 56,7 × 54,3 |
| • Dimensions in packaging | 64,4 × 66,0 × 66,5 |



EH 6324 W

Touch control INTELLIGENT SYSTEM Teleskop INOX Anti touch

White glass with bevels

Design

- Product line GRAND CHEF
- Elegant door handle INOX
- Panoramic inner glass with recipe table

Features

- Tangential circulation system
- Turnable rotisserie with chromed frame and removable handle
- Shelf support chromed rails
- Telescopic extension system **Teleskop** – 1-fold used in every level, optional up to 3-fold
- 5 Rack levels



EH 6324 G

Touch control INTELLIGENT SYSTEM Teleskop INOX Anti touch

Grey glass with bevels

Equipment

- 2 enamelled trays with **Easy-clean** antiallergic enamel
- 1 multifunction chromed roast shelf
- 1 chromed handle for trays

Control

- Electronic sensor-controlled programmer **Intelligent System** with metal rotary knobs
- Electronic sensor-controlled programmer **Touch control**
- Multifunction **LED**-display

Multi 8



Comfort

- **XXL** Multifunctional electric oven **Multi 8**
- **8 operating modes**
- **Catalytic self-cleaning**
- **Easy-clean** antiallergic enamel
- Removable door and inner glass
- Cold front – **3 glasses** oven door
- Special **THERMO-REFLECTIVE** glass

Technical specifications

- | | |
|---|----------|
| • Energy efficiency | A |
| • Gross capacity, L | 79 |
| • Net capacity according to EU standards, L | 73 |
| • Total power, kW | 2,56 |
| • Net weight, kg | 42,0 |
| • Gross weight, kg | 46,0 |

Dimensions H × W × D (cm)

- | | |
|---------------------------|--------------------|
| • Oven dimensions | 59,4 × 59,4 × 55,6 |
| • Niche dimensions | 55,8 × 56,7 × 54,3 |
| • Dimensions in packaging | 64,4 × 66,0 × 66,5 |

GRAND CHEF

ELECTRIC OVENS

ART DÉCO

Pyrolytic ovens with joystick knobs

Multi 11



EH 6426 AD

Antique Gold *Teleskop* **INTELLIGENT SYSTEM**
Black glass

Design

- Produkt line **ART DÉCO**
- Door handle and metal fittings **Antique Gold**
- **Art Déco** – leather covered handle's rod, metal parts **Antique Gold** with convex coat of arms
- Panoramic inner glass with recipe table

Features

- Tangential circulation system
- Shelf support chromed rails
- 5 Rack levels
- Telescopic extension system **Teleskop** – 1-fold used in every level, optional up to 3-fold

Equipment

- 1 enamelled tray with **Easy-clean** antiallergic enamel
- 1 multifunction chromed roast shelf
- 1 **Pizza stone** – round Ø 34 cm



EH 6426 EifAD

Antique Gold *Teleskop* **INTELLIGENT SYSTEM**
Ivory colored glass

Control

- Electronic sensor-controlled programmer **Intelligent System** with solid joysticks-rotary knobs **Antique Gold**
- Multifunction **LED**-display

Comfort

- **XXL** Multifunctional electric oven **Multi 11** with **pyrolytic** function
- **10 heating modes**
- **Pyrolytic clean function**
- **Easy-clean** antiallergic enamel
- Cold front – **4 Glasses** oven door
- Special **THERMO-REFLECTIVE** glass

Technical specifications

- Energy efficiency **A**
- Gross capacity, L 80
- Net capacity according to EU standards, L 70
- Total power, kW 3,0
- Net weight, kg 42,3
- Gross weight, kg 45,2

Dimensions H × W × D (cm)

- Oven dimensions 59,5 × 59,5 × 55,6
- Niche dimensions 59,5 × 56,0 × 56,0
- Dimensions in packaging 67,5 × 70,0 × 65,0



ART DÉCO



ELECTRIC OVENS

Empire

Electric oven with electromechanical programmer + Knobs control

Multi 8 



EH 6355 Em

Bronze Teleskop

Anthracite colored enamel

Design

- Product line **Empire**
- Enameled metal door and control panel in colors: Anthracite, Ivory, Bordeaux
- Analog clock
- Elegant massive metal door handle **Bronze**
- Panoramic inner glass with recipe table

Features

- Tangential circulation system
- Turnable rotisserie with chromed frame and removable handle
- Shelf support chromed rails
- Telescopic extension system **Teleskop** – 1 level, optional up to 3 levels
- 5 Rack levels

Equipment

- 1 enamelled baking tray
- 1 enamelled baking pan
- 1 multifunction roast shelf
- 1 chromed handle for Trays



EH 6355 ElfEm

Bronze Teleskop

Ivory colored enamel

Control

- Analogue control
- Electromechanical programmer with metal rotary knobs
- Elegant ergonomic metal knobs **Bronze**
- Child safety lock

Comfort

- Multifunctional electric oven **Multi 8**
- **7 heating modes**
- **1 defrosting mode**
- Easy-clean anti-allergic enamel
- Cold front — **3 glasses** oven door
- Special thermo-reflective glass **THERMO-REFLECTIVE**



EH 6355 RotEm

Bronze Teleskop

Bordeaux colored enamel

Technical specifications

- Energy efficiency class **A**
- Oven capacity, L. 67
- Grill power, kW 2,25
- Bottom heating element, kW 1,250
- Upper heating element, kW 1,8
- Lighting, kW 0,025
- Total power, kW 2,56
- Net weight, kg 39,00
- Gross weight, kg 43,50

Dimensions H x W x D (cm)

- Oven dimensions 59,4 x 59,4 x 55,6
- Niche dimensions 55,8 x 56,7 x 54,3
- Dimensions in packaging 64,4 x 66,0 x 66,5

Empire



ELECTRIC OVENS

Electric oven with electromechanical programmer + Knobs control

*Belle
Epoque*

Multi 8 



EH 6424 BE Eco

Antique Gold Teleskop

Anthracite colored enamel



EH 6424 EifBE Eco

Antique Gold Teleskop

Ivory colored enamel



EH 6424 BluBE Eco

Antique Gold Teleskop

Azure blue colored enamel



EH 6424 RotBE Eco

Antique Gold Teleskop

Bordeaux colored enamel



EH 6424 GrBE Eco

Antique Gold Teleskop

Grey colored enamel

Design

- Produkt line *Belle Epoque*
- Door handle and metal fittings **Antique Gold**
- **Art Déco** – leather covered handle's rod, metal parts **Antique Gold** with convex coat of arms
- Inner glass with recipe table

Features

- Tangential circulation system
- Turnable rotisserie with chromed frame and removable handle
- Shelf support chromed rails
- 5 Rack levels Teleskopauszugssystem
- Telescopic extension system **Teleskop** – 1-fold used in every level, optional up to 3-fold

Equipment

- 1 enamelled tray with **Easy-clean** antiallergic enamel
- 1 multifunction chromed roast shelf
- 1 chromed handle for trays
- 1 **Pizza stone** – round Ø 34 cm

Control

- Electromechanical programmer with metal rotary knobs **Antique Gold**
- Electronic-analogue timer with alarm and child lock funktions

Comfort

- Multifunctional electric oven **Multi 8**
- **8 operating modes**
- **Catalytic self-cleaning**
- **Easy-clean** antiallergic enamel
- Cold front – **2 glasses** oven door
- Special **THERMO-REFLECTIVE** glass

Technical specifications

- | | |
|---|----------|
| • Energy efficiency | A |
| • Gross capacity, L | 68 |
| • Net capacity according to EU standards, L | 63 |
| • Total power, kW | 3,0 |
| • Net weight, kg | 31,6 |
| • Gross weight, kg | 35,0 |

Dimensions H × W × D (cm)

- | | |
|---------------------------|--------------------|
| • Oven dimensions | 59,0 × 59,0 × 54,0 |
| • Niche dimensions | 59,5 × 56,0 × 56,0 |
| • Dimensions in packaging | 65,0 × 65,5 × 66,0 |

*Belle
Epoque*



GAS OVENS

Grand CHEF



Gas ovens with metal rotary knobs



EG 6372

Gas-Control
Teleskop



INTELLIGENT
SYSTEM
INOX
Anti touch

Stainless steel with Anti touch-effect/ black glass

Design

- Produkt line **Grand CHEF**
- Door handle INOX
- Panoramic inner glass with recipe table

Features

- Tangential circulation system
- Turnable rotisserie with chromed frame and removable handle
- Shelf support chromed rails
- Telescopic extension system **Teleskop** – 1-fold used in every level, optional up to 3-fold
- 5 Rack levels

Equipment

- 1 enamelled tray with **Easy-clean** antiallergic enamel
- 1 multifunction chromed roast shelf
- 1 chromed handle for trays



EG 6374 Sp

Gas-Control
Teleskop



INTELLIGENT
SYSTEM

Black mirror glass with bevels

Control

- Electronic sensor-controlled programmer **Intelligent System** with metal rotary knobs
- Electronic sensor-controlled programmer **Touch control**
- Multifunction **LED**-display

Comfort

- **XXL** Multifunctional gas oven with fan, bottom heat, infrared grill
- **Catalytic self-cleaning**
- One-hand ignition in rotary knob
- Flame failure safety device
- Electric grill
- **Easy-clean** antiallergic enamel
- Convection
- Removable door and inner panel
- Cold front – **3 glasses** oven door
- Special **THERMO-REFLECTIVE** glass



EG 6374 W

Gas-Control
Teleskop



INTELLIGENT
SYSTEM

White glass with bevels

Technical specifications

- Energy efficiency **A**
- Gross capacity, L 79
- Net capacity according to EU standards, L 73
- Total power, kW 1,8
- Net weight, kg 37,2
- Gross weight, kg 41,0

Dimensions H x W x D (cm)

- Oven dimensions 59,4 x 59,4 x 55,6
- Niche dimensions 55,8 x 56,7 x 54,3
- Dimensions in packaging 64,4 x 66,0 x 66,5



Grand CHEF

GAS OVENS

Empire

Electric oven with electromechanical programmer + Knobs control



EG 6345 Em

Gas-Control **Bronze** Teleskop **Ignition by knob**

Anthracite colored enamel

Design

- Product line **Empire**
- Enamelled metal door and control panel in colors: Anthracite, Ivory, Bordeaux
- Analog clock
- Elegant massive metal door handle **Bronze**
- Panoramic inner glass with recipe table

Features

- Tangential circulation system
- Turnable rotisserie with chromed frame and removable handle
- Shelf support chromed rails
- Telescopic extension system **Teleskop** – 1 level, optional up to 3 levels
- 5 Rack levels



EG 6345 ElfEm

Gas-Control **Bronze** Teleskop **Ignition by knob**

Ivory colored enamel

Equipment

- 1 enamelled baking tray
- 1 enamelled baking pan
- 1 multifunction roast shelf
- 1 chromed handle for Trays

Control

- Analogue control
- Electromechanical programmer with metal rotary knobs
- Elegant ergonomic metal knobs **Bronze**
- Child safety lock

Comfort

- One-hand ignition in rotary knob
 - Flame failure safety device
 - Electric grill
 - Easy-clean anti-allergic enamel
 - Cold front — **3 glasses** oven door
 - Special thermo-reflective glass
- THERMO-REFLECTIVE**



EG 6345 RotEm

Gas-Control **Bronze** Teleskop **Ignition by knob**

Bordeaux colored enamel

Technical specifications

- Energy efficiency class **A**
- Oven capacity, L. 67
- Grill power, kW 2,25
- Bottom gas burner, kW 2,5
- Lighting, kW 0,025
- Total power, kW 2,56
- Net weight, kg 38,00
- Gross weight, kg 42,5

Dimensions H × W × D (cm)

- Oven dimensions 59,4 × 59,4 × 56,6
- Niche dimensions 55,8 × 56,7 × 54,3
- Dimensions in packaging 64,4 × 66,0 × 66,5

ELECTRIC KETTLES



WK 2000 Em

Design

- Produkt line **Empire**
- Vintage, bell shape, lid and metal elements
- **Bronze** cordless boiling jar

Heating element

- Electric, hidden – prevents limescale deposits



WK 2000 ElfEm

Safety

- Automatic shutdown, dry run protection

Comfort

- 360° rotation on base, cable storage in base, **LED** indicator



WK 2000 RotEm

Capacity

- 2,0 liters

Power

- 1800 W

Empire

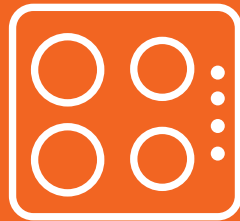

Hobs



GLASS CERAMIC HOBS

Induction hobs

Efficiency

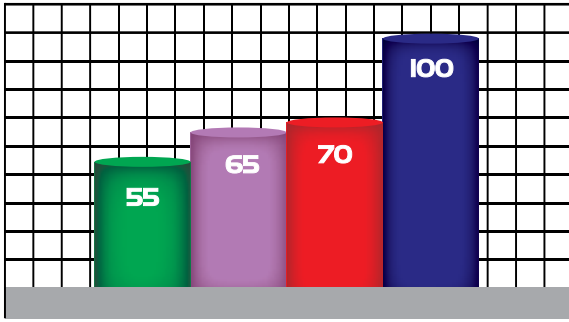

■ Gas ■ Electrics
■ Glass ceramic ■ Induction

Heating rate

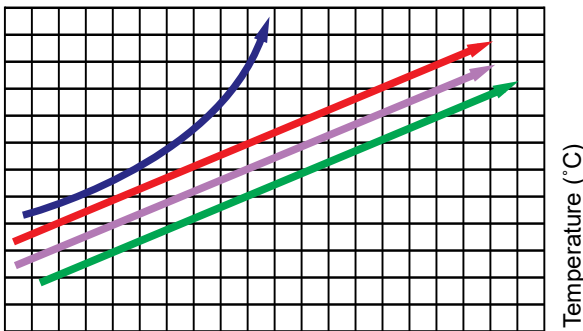

Time (min)

Comparative diagrams of efficiency and heating rate for the hobs of different types

- **Induction heating** — the most innovative solution in the area of the glass ceramic hobs.

- **Induction hob** is the smartest hob. Automatic power on-off function- the hob will be activated only if the pans are on the surface. If the pan is standing only on the half of the cooking surface, only this half will be heated.

- **The fastest heating rate:** 4 liters Water can be boiled in only 9 minutes.

- **The fastest reaction and sensitive control** — More comfortable than by other regular gas hobs.

- **The best time and energy save** — Compared to other types of hobs, the energy consumption will be reduced by minimum 30%.

- **The best way of cooking** — It combines all the advantages of the electric and gas hobs

- **The cleanest surface** — It will never burn something, because the surface of the hob stays cool.

It will be heated only the place, where a dish stands. For cleaning is it enough to wipe the surface with a damp cloth.

- **The simplest operation** — With a slight finger touch you can control all processes. With the **PAUSE** feature you can temporarily stop the cooking process and then continue it again.

- **The safest cooking surface** — If you remove a pan from the surface of the hob, it will become cold immediately.

There is no more risk of unintentional on/off switching.

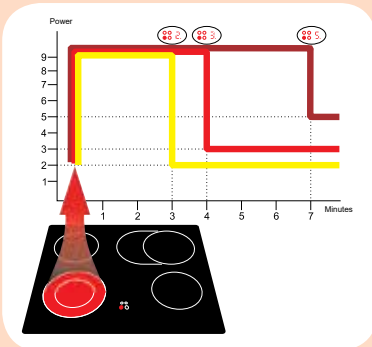

Glass Ceramic Hobs Hi-Light

Flash heating

The glass ceramic hobs *Kaiser* with the **Hi-Light** heating elements use the **flash heating** system. The maximum temperature will be reached in few seconds and then it will be reduced to the selected temperature. This system reduces the heating time of the cooking hob, so the energy consumption will be reduced too. The glass ceramic hobs are also distinguished by their elegant design.

Sensor Touch control

makes the control of our domestic appliances especially comfortable. **Touch control** of the ceramic surfaces ensures the reliable operation and easy maintenance. The smooth panel without any convex buttons is also an attractive design element. The cleaning of the surfaces with the full sensor operation **Touch control** is very simple and fast, because they do not have any convex elements. After simple wiping with a cloth or a napkin, the surface looks shiny and clean.



GLASS CERAMIC HOBS

Practical and sensible

FREE ZONE
Power INDUCTION

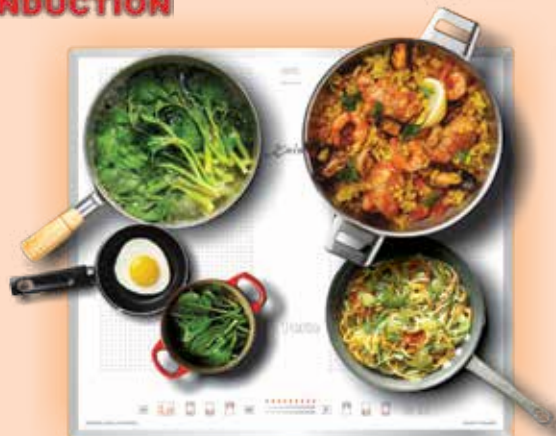
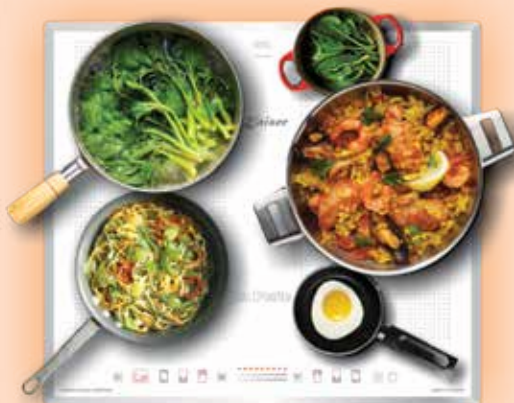

Ceramic induction hob with free heating zones, which allow to place pans anywhere without worrying about the number and size

- Number, shape and size of dishes are unimportant
- Full freedom of movement of cookware on the heating field
- Activation of the cooking zone only under the cookware
- Ultra-fast heating function **Power**
- Function **KEEP WARM**
- Timer/ minute counter for each of the four cooking zones
- System for automatic shutdown **Safety Guard**

Not only black – cooking hobs with artistic design



Decorate your kitchen with a glass ceramic hob. These hobs have memorable design, graphics which applied under the glass surface and therefore protected from abrasion. Traces that may occur with prolonged use of standard surfaces with black colouring on these models can not be seen. The hobs fit well into all kinds of kitchen designs.

The dual heating zones – round and oval (for roasting pans) allow to prepare a variety of meals in cooking ware with different bottom diameters and with oblong bottoms.

Fully sensor electronic controls Full touch provides accurate power setting, function Child lock, automatic shutdown function Safety guard, as well as LED indication of working zones of heating and residual heat.



Design cooking hobs with different graphics boost spirits and as a result – the quality of prepared dishes.





1

2

3

4

Power

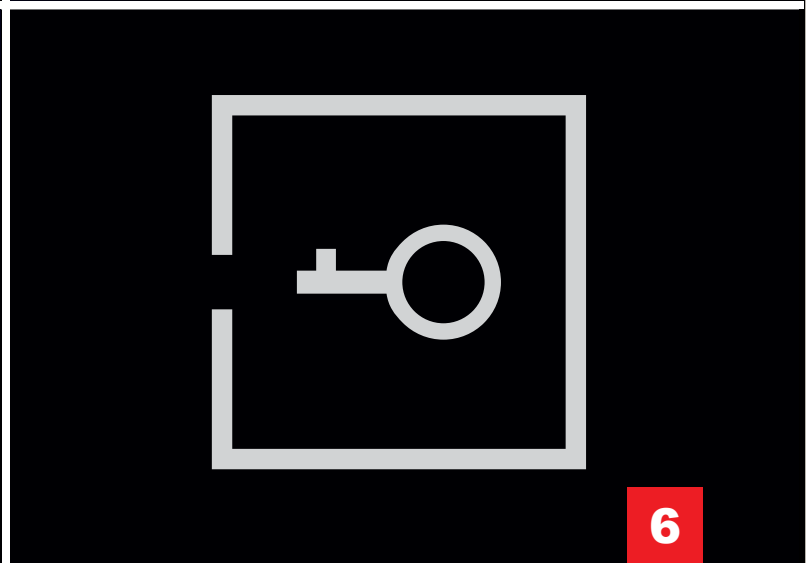
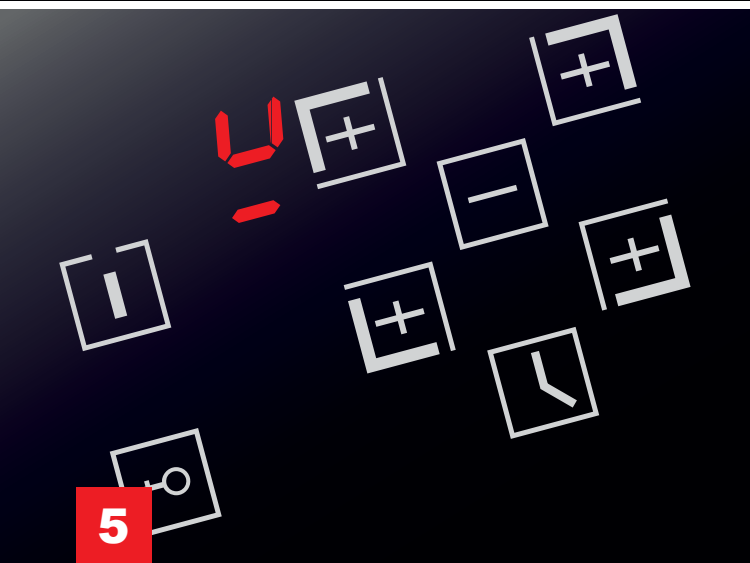

5

6

7

8





KCT 95 FI LaPerle

FREE ZONE Power INDUCTION

POWER-SLIDE

Full touch Logic control 90 cm

Induction Touch control

Keep Warm Safety Guard



Black glass ceramic SCHOTT with bevels

Design

- Produkt line **La Perle**

Controls

- Electronic **Logic control** switch with programmer
- Cooking zone control **Power Slide**
- **LED**-displays
- Child safety lock
- Timer for each cooking zone
- Minute minder

Komfort

- **FREE ZONE** – Heating the dishes of any size over the entire area of the heating zone
- Booster function **Power** for all cooking zones
- Induction cooking zones, self-adjustable according to size of an utensil
- Automatic shutdown system **Safety Guard**
- Residual heat indicators
- Shock resistant ceramics, glass with durable graphics
- Easy to clean

Technical specifications

Induction zones (**Power**-function):

- 4 zones 19,5 × 22,0 cm 1,8 kW (3,0 kW)
- 2 zones 39,0 × 20,0 cm 3,0 kW (4,0 kW)
- 1 zone Ø 28,0 cm 1,8 kW (3,0 kW)
- Total power, kW 10,8
- Net weight, kg 19,0
- Gross weight, kg 21,0

Dimensions (H × W × D, cm)

- Unit dimensions 5,5 × 90,0 × 52,0
- Cut-out 87,5 × 49,5
- Dimensions in packaging 14,5 × 105,0 × 67,5

Freezone induction hobs

with free heating zones, which allow to place ceramic induction hob cookware arbitrarily, without worrying about the number and size

1 Touch control system

The modern technology. Delicate, precise and punctual control.

2 «Cold» surface

The surface out of a zone of contact of tableware with a heating field remains «cold» that provides high safety and ease of cleaning.

3 Function Power

Within several minutes the power of a heating zone is spreading entirely or partially to another. For example: from 1.5 to 2.0 kW, 2.1 to 2.8 kW, 2.6 to 3.6 kW which leads to extremely fast heating.

4 Full touch sensor control.

5 Automatic tableware detection

The ware made not from a ferromagnetic material won't heat up. A certainty that distinguishes the skillful use of technology for the consumer's benefit.

6 System lock (Child lock)

To avoid an undesirable operation the control panel can be blocked. Tranquillity for a worry-free life and safe, confident use.

7 Residual heat indicator

Indicates when each cooking area is hot after use. The indication is extinguished if the temperature falls below 60 °C.

8 Glass ceramic hob

With the presence of a frame, facilitates the flush mounting of the work surfaces made of any material in the kitchen. An esthetic pleasure combined with greater ease of cleaning.

INDUCTION GLASS CERAMIC HOBS

La Perle



KCT 77 FI La Perle

Induction Safety Guard Full touch
POWER-SLIDE 77 cm INTELLIGENT SYSTEM

Black glass ceramic SCHOTT with bevels

Design

- Produkt line **La Perle**

Controls

- Electronic **Intelligent System** switch with programmer
- Cooking zone control **Power Slide**
- **LED**-displays
- Child safety lock
- Timer for each cooking zone
- Minute minder

Comfort

- **FREE ZONE** – Heating the dishes of any size over the entire area of the heating zone
- Booster function **Power** for all cooking zones
- Induction cooking zones, self-adjustable according to size of an utensil
- Automatic shutdown system **Safety Guard**
- Residual heat indicators
- Shock resistant ceramics, glass with durable graphics
- Easy to clean

FREE ZONE Power INDUCTION

Technical specifications

Induction zones (**Power**-function):

- 4 zones 19,5 × 22,0 cm 1,8 kW (2,3 kW)
- 2 zones 39,0 × 20,0 cm 1,8 kW (3,0 kW)
- 1 zone Ø 21,0 cm 2,0 kW
- Total power, kW 7,8
- Net weight, kg 19,0
- Gross weight, kg 21,0

Dimensions (H × W × D, cm)

- Unit dimensions 5,8 × 77,0 × 52,0
- Cut-out 74,0 × 49,5
- Dimensions in packaging 14,5 × 105,0 × 67,5



KCT 67 FI La Perle

Induction 60 cm Safety Guard
POWER-SLIDE INTELLIGENT SYSTEM Touch control

Black glass ceramic SCHOTT with bevels

Design

- Produkt line **La Perle**



KCT 67 FIW La Perle

Induction 60 cm Safety Guard
POWER-SLIDE INTELLIGENT SYSTEM Touch control

White glass ceramic with bevels

Controls

- Electronic **Intelligent System** switch with programmer
- Cooking zone control **Power Slide**
- **LED**-displays
- Child safety lock
- Timer for each cooking zone
- Minute minder

Comfort

- **FREE ZONE** – Heating the dishes of any size over the entire area of the heating zone
- Booster function **Power** for all cooking zones
- Induction cooking zones, self-adjustable according to size of an utensil
- Automatic shutdown system **Safety Guard**
- Residual heat indicators
- Shock resistant ceramics, glass with durable graphics
- Easy to clean

Technical specifications

Induction zones (**Power**-function):

- 2 zones 20,0 × 20,0 cm 1,5 kW (2,0 kW)
- 2 zones 20,0 × 20,0 cm 2,0 kW (2,6 kW)
- 2 zones 40,0 × 20,0 cm 2,5 kW (2,8 kW)
- Total power, kW 7,2
- Net weight, kg 9,0
- Gross weight, kg 11,2

Dimensions (H × W × D, cm)

- Unit dimensions 5,5 × 59,0 × 52,0
- Cut-out 56,0 × 49,0
- Dimensions in packaging 11,5 × 69,0 × 64,5

La Perle



- Size, quantity and shape of the dishes are not important
- Complete freedom of placement of cookware on heating field
- Cooking zone activation just under cookware
- Superfast heating function Power
- Warming function Keep Warm
- Timer / minute counter for each of four cooking zones
- Automatic shutdown system
- Safety Guard
- Residual heat indicator



INDUCTION GLASS CERAMIC HOBS

Avantgarde PRO



KCT 9690 FI Avant.PRO

Moire glass ceramic SCHOTT with front bevel

Design

- Produkt line *Avantgarde*

Controls

- Electronic **Intelligent System** switch with programmer
- Cooking zone control **Power Slide**
- **LED** displays
- Child safety lock
- Timer for each cooking zone
- Minute minder

4 x 4 FREE ZONE Power INDUCTION

Induction
Safety Guard
POWER-SLIDE
90 cm

INTELLIGENT SYSTEM
Full touch
Teppan Yaki

Comfort

- **FREE ZONE** – Heating the dishes of any size over the entire area of the heating zone
- **Teppan Yaki** – Heating the dishes of any size over the entire area of the heating zone
- **4x4** - optimal use of whole heating area
- Booster function **Power** for all cooking zones
- Induction cooking zones, self-adjustable according to size of an utensil
- Automatic shutdown system **Safety Guard**
- Residual heat indicators
- Shock resistant ceramics, glass with durable graphics
- Easy to clean

Technical specifications

Induction zones (**Power**-function):

- 4 zones 20,0 x 22,0 cm 2,0 kW (3,0 kW)
- 2 zones 40,0 x 20,0 cm 3,0 kW (3,6 kW)
- 1 zone 40,0 x 44,0 cm 4,8 kW (5,6 kW)
- 2 zones 28,0 x 20,0 cm 2,0 kW (3,0 kW)
- 1 zone 28,0 x 40,0 cm 3,0 kW (3,6 kW)
- Total power, kW 10,8
- Net weight, kg 19,0
- Gross weight, kg 21,0

Dimensions (H x W x D, cm)

- Unit dimensions 5,5 x 90,0 x 52,0
- Cut-out 87,5 x 49,5
- Dimensions in packaging 13,5 x 97,0 x 62,0



KCT 6690 FI Avant.PRO

Induction Safety Guard 60 cm
Full touch INTELLIGENT SYSTEM POWER-SLIDE

Moire glass ceramic SCHOTT with front bevel

Design

- Produkt line *Avantgarde*

Controls

- Electronic **Intelligent System** switch with programmer
- Cooking zone control **Power Slide**
- **LED** displays
- Child safety lock
- Timer for each cooking zone
- Minute minder

Comfort

- **FREE ZONE** – Heating the dishes of any size over the entire area of the heating zone
- Booster function **Power** for all cooking zones
- **4x4** - optimal use of whole heating area
- Induction cooking zones, self-adjustable according to size of an utensil
- Automatic shutdown system **Safety Guard**
- Residual heat indicators

- Shock resistant ceramics, glass with durable graphics
- Easy to clean

Technical specifications

Induction zones (**Power**-function):

- 4 zones 20,0 x 22,0 cm 2,0 kW (3,0 kW)
- 2 zones 40,0 x 20,0 cm 3,0 kW (3,6 kW)
- 1 zone 40,0 x 44,0 cm 4,8 kW (5,6 kW)
- Total power, kW 7,2
- Net weight, kg 9,0
- Gross weight, kg 11,2

Dimensions (H x W x D, cm)

- Unit dimensions 5,5 x 59,0 x 52,0
- Cut-out 56,0 x 49,5
- Dimensions in packaging 13,5 x 67,5 x 62,0



KCT 6730 FIG

Induction Safety Guard 60 cm
INTELLIGENT SYSTEM Touch control Power Circle

Grey glass ceramic with bevels

Design

- Produkt line *Avantgarde*

Controls

- Electronic **Intelligent System** switch with programmer
- Cooking zone control **Power Circle**
- **LED**-displays
- Child safety lock
- Timer for each cooking zone
- Minute minder

Comfort

- **FREE ZONE** – Heating the dishes of any size over the entire area of the heating zone
- Booster function **Power** for all cooking zones
- Induction cooking zones, self-adjustable according to size of an utensil
- Automatic shutdown system **Safety Guard**
- Residual heat indicators
- Shock resistant ceramics, glass with durable graphics
- Easy to clean

Technical specifications

Induction zones (**Power**-function):

- 2 zones 20,0 x 20,0 cm 1,5 kW (2,0 kW)
- 2 zones 20,0 x 20,0 cm 2,0 kW (2,6 kW)
- 2 zones 40,0 x 20,0 cm 2,5 kW (2,8 kW)
- Total power, kW 7,2
- Net weight, kg 9,0
- Gross weight, kg 11,2

Dimensions (H x W x D, cm)

- Unit dimensions 5,5 x 59,0 x 52,0
- Cut-out 56,0 x 49,0
- Dimensions in packaging 11,5 x 69,0 x 64,5

Avantgarde PRO

INDUCTION GLASS CERAMIC HOBS

Grand CHEF



KCT 6705 FI

Induction Safety Guard Touch control
POWER-SLIDE 60 cm

Black glass ceramic SCHOTT with bevels

Design

- Produkt line **Grand CHEF**
- Black glass ceramic **SCHOTT** with bevels

Controls

- Electronic **Intelligent System** switch with programmer
- Cooking zone control **Power Slide**
- **LED** displays
- Child safety lock
- Timer for each cooking zone
- Minute minder

Comfort

- Booster function **Power** for all cooking zones
- Induction cooking zones, self-adjustable according to size of an utensil
- Automatic shutdown system **Safety Guard**
- Residual heat indicators
- Shock resistant ceramics, glass with durable graphics
- Easy to clean

Technical specifications

Induction zones (**Power**-function):

- 2 zones Ø 16,0 cm 1,2 kW (1,5 kW)
- 1 zone Ø 18,0 cm 2,0 kW (2,6 kW)
- 1 zone Ø 21,0 cm 2,2 kW (3,6 kW)
- Total power, kW 7,2
- Net weight, kg 9,0
- Gross weight, kg 11,2

Dimensions (H x W x D, cm)

- Unit dimensions 5,5 x 59,0 x 52,0
- Cut-out 56,0 x 49,0
- Dimensions in packaging 11,5 x 69,0 x 64,5



KCT 6736 FI

Induction Safety Guard Touch control
POWER-SLIDE 60 cm

Black glass ceramic SCHOTT with bevels

Design

- Produkt line **Grand CHEF**

Controls

- Electronic **Intelligent System** switch with programmer
- Cooking zone control **Power Slide**
- **LED** displays
- Child safety lock
- Timer for each cooking zone
- Minute minder

Comfort

- Booster function **Power** for all cooking zones
- Induction cooking zones, self-adjustable according to size of an utensil
- Automatic shutdown system **Safety Guard**
- Residual heat indicators
- Shock resistant ceramics, glass with durable graphics
- Easy to clean

Technical specifications

Induction zones (**Power**-function):

- 1 zone Ø 16,0 cm 1,2 kW (1,5 kW)
- 1 zone Ø 21,0 cm 2,2 kW (3,6 kW)
- 1 zone Ø 28,0 cm 2,3 kW (3,0 kW)
- Total power, kW 7,2
- Net weight, kg 8,5
- Gross weight, kg 10,0

Dimensions (H x W x D, cm)

- Unit dimensions 5,5 x 59,0 x 52,0
- Cut-out 56,0 x 49,0
- Dimensions in packaging 11,5 x 69,0 x 64,5

Grand CHEF

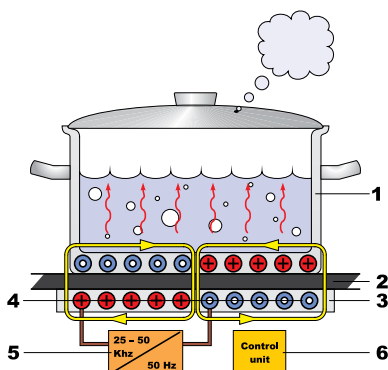

The working principle

The functional principle of the induction hob is based on the use of magnetic field energy.

Under the glass ceramic surface is a high frequency induction coil, which generates the alternating magnetic field.

This alternating field generates eddy currents in the bottom of a ferromagnetic pot and heats the pot content.

1. Tableware with the ferromagnetic bottom
2. Glass ceramic hob
3. Isolation
4. Induction coil
5. Frequency converter
6. Electronic control unit

INDUCTION GLASS CERAMIC HOBS **DOMINO**



KCT 3726 FI

Induction Safety Guard Touch control
30 cm

Black glass ceramic

Design

- Produkt line **GRAND CHEF**



KCT 3726 FIW

Induction Safety Guard Touch control
30 cm

White glass ceramic

Controls

- Electronic **Intelligent System** switch with programmer
- **LED** displays
- Child safety lock
- Timer for each cooking zone
- Minute minder

Comfort

- Booster function **Power** for all cooking zones
- Induction cooking zones, self-adjustable according to size of an utensil
- Automatic shutdown system **Safety Guard**
- Residual heat indicators
- Shock resistant ceramics, glass with durable graphics
- Easy to clean

Technical specifications

Induction zones (**Power**-function):

- 1 zone Ø 18,0 cm 2,0 kW (2,6 kW)
- 1 zone Ø 14,0 cm 1,5 kW (1,9 kW)
- Total power, kW 3,5
- Net weight, kg 4,6
- Gross weight, kg 5,6

Dimensions (H × W × D, cm)

- Unit dimensions 5,5 × 28,8 × 52,0
- Cut-out 26,8 × 50,0
- Dimensions in packaging 14,2 × 61,0 × 39,2

GRAND CHEF

INDUCTION GLASS CERAMIC HOBS



KCT 6506 FI Ära

Induction Safety Guard Full touch
POWER-SLIDE 60 cm

Glass ceramic SCHOTT with bevels

Design

- Model range **Ära**
- Cave painting motive

Controls

- Electronic sensor control **Full Touch**
- Power control **Power Slide**
- **LED** displays
- Child safety lock
- Timer for each cooking zone
- Minute minder

Comfort

- Booster function **Power** for all cooking zones
- Induction cooking zones, self-adjustable according to size of an utensil
- Automatic shutdown system **Safety Guard**
- Residual heat indicators
- Shock resistant ceramics, glass with durable graphics
- Easy to clean

Equipment

- Clean scraper

Technical specifications

Induction heating elements:

- 1 zone Ø 21,0 cm 2,2 kW (3,6 kW)
- 1 zone Ø 18,0 cm 2,2 kW (3,0 kW)
- 2 zones Ø 15,0 cm 1,4 kW (2,0 kW)
- Total power, kW 7,2
- Net weight, kg 13,56
- Gross weight, kg 15,80

Dimensions (H × W × D, cm)

- Unit dimensions 5,5 × 59,0 × 52,0
- Cut-out 56,0 × 49,0
- Dimensions in packaging 11,5 × 69,0 × 64,5

Ära

Advantages of induction hobs.

The induction hobs have many advantages over the conventional gas and electric hobs. Induction hobs ensure the highest accuracy of heating. They respond very fast to every change of settings and any temperature changing takes place immediately. Although the heating time is much shorter, it can be saved up to 10% energy.

The **Power** function allows to share the power of one heating field with the neighbor heating field. The Tableware will be heated only when a pan with the ferromagnetic bottom stand on the hotplate. The heat production will be stoped immediately, if the pot will be taken out from the hob. The hob surface will not be heated by the

induction process but only by the heated pan. That is why the burning of spilled food is excluded. After turning off it will become cold in a few minutes.

Easy maintenance:

The surface of an induction hob is perfectly smooth, so a simple wiping with a damp cloth is enough to make it clean.

INDUCTION GLASS CERAMIC HOBS



KCT 6723 FI BluBE

Induction **60 cm** **Power Circle**
Safety Guard **Touch control**

Azure glass ceramic

Design

- Produkt line *Belle Époque*

FREE ZONE Power INDUCTION

Controls

- Electronic **Intelligent System** switch with programmer
- Cooking zone control **Power Circle**
- **LED** displays
- Child safety lock
- Timer for each cooking zone
- Minute minder

Comfort

- **FREE ZONE** – Heating the dishes of any size over the entire area of the heating zone
- Booster function **Power**
- Induction cooking zones, self-adjustable according to size of an utensil
- Automatic shutdown system **Safety Guard**
- Residual heat indicators
- Shock resistant ceramics, glass with durable graphics
- Easy to clean

Technical specifications

Induction zones (**Power**-function):

- 2 zones 20,0 × 20,0 cm 1,5 kW (2,0 kW)
- 2 zones 20,0 × 20,0 cm 2,0 kW (2,6 kW)
- 2 zones 40,0 × 20,0 cm 2,5 kW (2,8 kW)
- Total power, kW 7,0
- Net weight, kg 9,0
- Gross weight, kg 11,2

Dimensions (H × W × D, cm)

- Unit dimensions 5,5 × 59,0 × 52,0
- Cut-out 56,0 × 49,0
- Dimensions in packaging 11,5 × 69,0 × 64,5

Belle Époque



KCT 6745 FI AD

Induction **Antique Gold** **Touch control**
Safety Guard **Power Circle**

Black glass ceramic

Design

- Produkt line **ART DÉCO**
- Metal fittings **Antique Gold**

Controls

- Electronic **Intelligent System** switch with programmer
- Cooking zone control **Power Circle**
- **LED** displays
- Child safety lock
- Timer for each cooking zone
- Minute minder



KCT 6745 FI EifAD

Induction **Antique Gold** **Touch control**
Safety Guard **Power Circle** **60 cm**

Ivory glass ceramic

Comfort

- **FREE ZONE** – Heating the dishes of any size over the entire area of the heating zone
- Booster function **Power**
- Induction cooking zones, self-adjustable according to size of an utensil
- Automatic shutdown system **Safety Guard**
- Residual heat indicators
- Shock resistant ceramics, glass with durable graphics
- Easy to clean

FREE ZONE Power INDUCTION

Technical specifications

Induction zones (**Power**-function):

- 2 zones 20,0 × 20,0 cm 1,5 kW (2,0 kW)
- 2 zones 20,0 × 20,0 cm 2,0 kW (2,6 kW)
- 2 zones 40,0 × 20,0 cm 2,5 kW (2,8 kW)
- Total power, kW 7,0
- Net weight, kg 9,0
- Gross weight, kg 11,2

Dimensions (H × W × D, cm)

- Gerätemaße 5,5 × 59,0 × 52,0
- Ausschnittmaße 56,0 × 49,0
- Verpackungsmaße 11,5 × 69,0 × 64,5

ART DÉCO



KCT 6395 IEm

Logic control Induction Touch control
Safety Guard 60 cm Bronze

Black glass ceramic

Design

- Produkt line **Empire**
- 1. Black/ 2. ivory glass ceramic front and rear solid metal plates **Bronze**
- Graphics and inscriptions **Bronze**

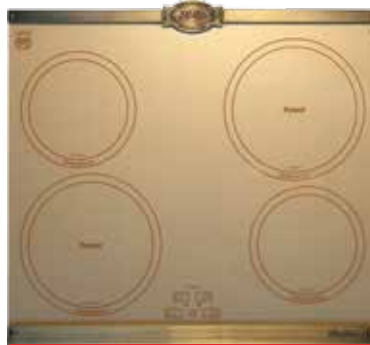

KCT 6395 IEIfEm

Logic control Induction Touch control
Safety Guard 60 cm Bronze

Ivory glass ceramic

Controls

- Electronic **Logic control** switch with programmer
- **LED** displays
- Child safety lock
- Timer for each cooking zone
- Minute minder

Comfort

- Booster function **Power** for 2 cooking zones
- Induction cooking zones, self-adjustable according to size of an utensil
- Automatic shutdown system **Safety Guard**
- Residual heat indicators
- Shock resistant ceramics, glass with durable graphics
- Easy to clean

Technical specifications

Induction zones (**Power**-function):

- 2 zones Ø 21,0 cm 2,2 kW (3,6 kW)
- 2 zones Ø 18,0 cm 2,2 kW
- Total power, kW 7,2
- Net weight, kg 12,7
- Gross weight, kg 15,3

Dimensions (H × W × D, cm)

- Gerätemaße 5,0 × 58,0 × 53,5
- Ausschnittmaße 56,0 × 49,3
- Verpackungsmaße 13,0 × 66,0 × 58,0



KCT 7795 FI Em

Induction Safety Guard INTELLIGENT SYSTEM
Touch control POWER-SLIDE 77 cm

Anthracite glass ceramic with front bevel

Design

- Produkt line **Empire**
- Graphics and inscriptions **Bronze**

Controls

- Electronic **Intelligent System** switch with programmer
- Cooking zone control **Power Slide**
- LED displays
- Child safety lock
- Timer for each cooking zone
- Minute minder



KCT 7795 FI IEIfEm

Induction Safety Guard INTELLIGENT SYSTEM
Touch control POWER-SLIDE 77 cm

Ivory glass ceramic with front bevel

Comfort

- **FREE ZONE** – Heating the dishes of any size over the entire area of the heating zone
- Booster function **Power**
- Induction cooking zones, self-adjustable according to size of an utensil
- Automatic shutdown system **Safety Guard**
- Residual heat indicators
- Shock resistant ceramics, glass with durable graphics
- Easy to clean



KCT 7795 FI RotEm

Induction Safety Guard INTELLIGENT SYSTEM
Touch control POWER-SLIDE 77 cm

Bordeaux glass ceramic with front bevel

Technical specifications

Induction zones (**Power**-function):

- 4 zones 20,0 × 20,0 cm 1,8 kW (3,0 kW)
- 2 zones 40,0 × 20,0 cm 3,0 kW (4,0 kW)
- 1 zone Ø 28,0 cm 2,0 kW
- Total power, kW 7,2
- Net weight, kg 12,7
- Gross weight, kg 15,3

Dimensions (H × W × D, cm)

- Unit dimensions 52,0 × 77,0 × 6,2
- Cut-out 74,0 × 49,5
- Dimensions in packaging 11,5 × 69,0 × 64,5

FREE ZONE
Power INDUCTION

Empire

Hi-Light + INDUCTION GLASS CERAMIC HOBS



KCT 6722 FI

Induction **Safety Guard** **60 cm**

Hi-Light **INTELLIGENT SYSTEM** **Touch control**

Black glass ceramic SCHOTT with bevels

Design

- Product line **GRAND CHEF**

Controls

- Electronic sensor control **Full touch**
- LED**-Displays
- Child safety lock
- Timer for each cooking zone
- Minute minder

Comfort

- Booster function **Power** for 2 cooking zones
- Induction cooking zones, self-adjustable according to size of dish
- QuickHeat-cooking zone **Hi Light**
- Automatic shutdown system **Safety Guard**
- Residual heat indicators
- Shock resistant ceramics, glass with durable graphics
- Easy to clean

Technical specifications

Induction heating elements:

- 1 zone Ø 18,0 cm 1,8 kW (2,3 kW)
- 1 zone Ø 18,0 cm 1,2 kW (1,5 kW)

Heating elements Hi Light:

- 1 zone Ø 22,0 cm 1,8 kW
- 1 zone Ø 16,5 cm 1,2 kW
- Total power; kW 6,8
- Net weight, kg 9,00
- Gross weight, kg 11,00

Dimensions (H × W × D, cm)

- Unit dimensions 6,5 × 59,0 × 52,0
- Cut-out 56,0 × 49,1
- Dimensions in packaging 14,2 × 61,0 × 39,3

GRAND CHEF

Hi-Light GLASS CERAMIC HOBS



KCT 6515 F Ära

INTELLIGENT SYSTEM **Touch control** **Hi-Light** **60 cm**

Safety Guard

Glass ceramic SCHOTT with bevels

Design

- Model range **Ära**
- Artistic design – **Cave Painting**

Controls

- Electronic sensor control **Full touch**
- Power control **Power Slide**
- LED**-Displays
- Child safety lock
- Timer for each cooking zone
- Minute minder

Comfort

- Triple heating zone
- Extendable oval zone
- QuickHeat-cooking zone **Hi Light**
- Automatic shutdown system **Safety Guard**
- Residual heat indicators
- Shock resistant ceramics, glass with durable graphics
- Easy to clean

Technical specifications

Hi-Light heating elements:

Heating elements Hi Light:

- 2 zones Ø 16,0 cm 1,2 kW
- 1 zone Ø 16,0 / 16,0 × 26,5 cm 1,1/2,0 kW
- 1 zone Ø 22,5 / 17,5 / 12 cm 2,3/ 1,6/ 0,8 kW
- Total power, kW 6,5
- Net weight, kg 9,5
- Gross weight, kg 11,5

Dimensions (H × W × D, cm)

- Unit dimensions 4,9 × 59,0 × 52,0
- Cut-out 56,0 × 49,0
- Dimensions in packaging 11,5 × 69,0 × 64,5

Ära



KCT 6515 F Herd

INTELLIGENT SYSTEM **Touch control** **Hi-Light** **60 cm**

Safety Guard

Glass ceramic SCHOTT with thin Inox frame

Design

- Model range **Herd**
- Artistic design – **Cast Iron Hob**

Controls

- Electronic sensor control **Full touch**
- Power control **Power Slide**
- LED**-Displays
- Child safety lock
- Timer for each cooking zone
- Minute minder

Comfort

- Triple heating zone
- Extendable oval zone
- QuickHeat-cooking zone **Hi Light**
- Automatic shutdown system **Safety Guard**
- Residual heat indicators
- Shock resistant ceramics, glass with durable graphics
- Easy to clean

Technical specifications

Hi-Light heating elements:

Heating elements Hi Light:

- 2 zones Ø 16,0 cm 1,2 kW
- 1 zone Ø 16,0 / 16,0 × 26,5 cm 1,1/2,0 kW
- 1 zone Ø 22,5 / 17,5 / 12 cm 2,3/ 1,6/ 0,8 kW
- Total power, kW 6,5
- Net weight, kg 9,5
- Gross weight, kg 11,5

Dimensions (H × W × D, cm)

- Unit dimensions 4,9 × 59,0 × 52,0
- Cut-out 56,0 × 49,0
- Dimensions in packaging 11,5 × 69,0 × 64,5

Herd

Hi-Light GLASS CERAMIC HOBS

Grand CHEF



KCT 6715 F

INTELLIGENT SYSTEM Touch control Hi-Light 60 cm



Safety Guard

Black glass ceramic SCHOTT with bevels

Design

- Model range **Grand CHEF**
- Glass ceramic **SCHOTT** with bevels

Controls

- Electronic sensor control **Full touch**
- Power control **Power Slide**
- **LED**-Displays
- Child safety lock
- Timer for each cooking zone
- Minute minder

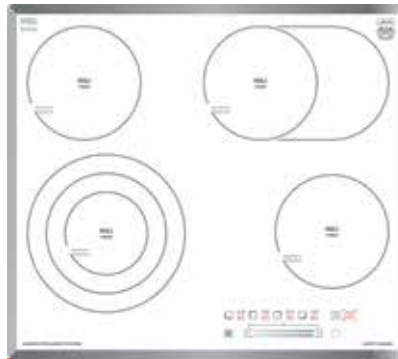

KCT 6715 F W

INTELLIGENT SYSTEM Touch control Hi-Light 60 cm



Safety Guard

White glass ceramic with bevels

Comfort

- Triple heating zone
- Extendable oval zone
- QuickHeat-cooking zone **Hi Light**
- Automatic shutdown system **Safety Guard**
- Residual heat indicators
- Shock resistant ceramics, glass with durable graphics
- Easy to clean

Technical specifications

Hi-Light heating elements:

Heating elements Hi Light:

- 2 zones Ø 16,0 cm 1,2 kW
- 1 zone Ø 16,0 / 16,0 × 26,5 cm 1,1/2,0 kW
- 1 zone Ø 22,5 / 17,5 / 12 cm 2,3/ 1,6/ 0,8 kW
- Total power, kW 6,5
- Net weight, kg 9,5
- Gross weight, kg 11,5

Dimensions (H × W × D, cm)

- Unit dimensions 5,2 × 59,0 × 52,0
- Cut-out 56,0 × 49,0
- Dimensions in packaging 11,5 × 65,0 × 56,0



KCT 4745 F

INTELLIGENT SYSTEM Touch control Hi-Light 45 cm



Safety Guard

Black glass ceramic SCHOTT with bevels ahead

Design

- Produkt line **Grand CHEF**

Controls

- Electronic **Intelligent System** switch with programmer
- **LED** displays
- Child safety lock
- Timer for each cooking zone
- Minute minder

Comfort

- **QuickHeat** cooking zones
- Automatic shutdown system **Safety Guard**
- Residual heat indicators
- Shock resistant ceramics, glass with durable graphics
- Easy to clean

Technical specifications

Hi-Light heating elements:

- 1 zone Ø 15,0 cm 1,2 kW
- 1 zones Ø 18,5 cm 1,8 kW
- 1 zone Ø 18,5 / 12,0 cm 2,2 / 1,0 kW
- Total power, kW 5,2
- Net weight, kg 9,0
- Gross weight, kg 11,0

Dimensions (H × W × D, cm)

- Unit dimensions 4,4 × 45,0 × 51,0
- Cut-out 42,0 × 49,0
- Dimensions in packaging 12,5 × 55,0 × 61,5

Hi-Light GLASS CERAMIC HOBS **DOMINO**



KCT 3721 F

INTELLIGENT SYSTEM Hi-Light  **Safety Guard**
30 cm

Black glass ceramic

Design

- Produkt line **GRAND CHEF**
- Glass ceramic **SCHOTT** with bevels

Controls

- Electronic **Intelligent System** switch with programmer
- **LED** displays
- Child safety lock
- Timer for each cooking zone
- Minute minder



KCT 3721 FW

INTELLIGENT SYSTEM Hi-Light  **Safety Guard**
30 cm

White glass ceramic

Comfort

- **QuickHeat** cooking zones
- Automatic shutdown system **Safety Guard**
- Residual heat indicators
- Shock resistant ceramics, glass with durable graphics
- Easy to clean

Technical specifications

Hi-Light heating elements:

- 1 zone Ø 16,5 cm 1,2 kW
- 1 zone Ø 20,0 / 12,0 cm 2,0 / 1,0 kW
- Total power, kW 3,2
- Net weight, kg 4,5
- Gross weight, kg 5,8

Dimensions (H × W × D cm)

- Unit dimensions 5,2 × 28,8 × 52,0
- Cut-out 26,8 × 50,0
- Dimensions in packaging 11,5 × 57,5 × 38,0

GRAND CHEF



KCT 6385 Em

Touch control Hi-Light   **Logic control**
Safety Guard **Bronze** 60 cm

Black glass ceramic

Design

- Produkt line **Empire**
- Glass ceramic front and rear solid metal plates **Bronze**

Controls

- Electronic sensor control **Full touch**
- **LED**-Displays
- Child safety lock
- Timer for each cooking zone
- Minute minder

Comfort

- 4 heating zones **Hi-Light**:
- 2 dual heating zones: oval, round
- Automatic shutdown system **Safety Guard**
- Residual heat indicators
- Shock proof ceramic with wear-resistant graphics
- Easy cleaning

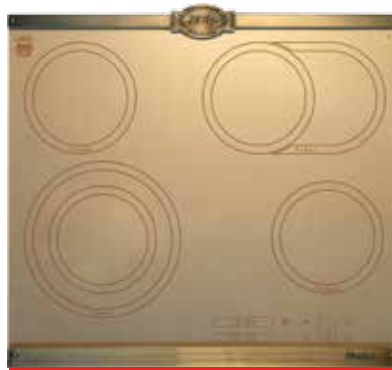

KCT 6385 ElEm

Touch control Hi-Light   **Logic control**
Safety Guard **Bronze** 60 cm

Ivory glass ceramic

Technical specifications

Hi-Light heating elements:

- 2 zones Ø 14,5 cm 1,2 kW
- 1 zone Ø 14,5 cm / 14,5 × 25,0 cm 1,1 / 2,0 kW
- 1 zone Ø 21,0 / 14,0 cm 2,2 / 1,0 kW
- Total power; kW 6,6
- Net weight, kg 8,6
- Gross weight, kg 10,6

Dimensions (H × W × D, cm)

- Unit dimensions 5,8 × 58,0 × 53,5
- Cut-out 56,0 × 49,3
- Dimensions in packaging 13,0 × 66,0 × 58,0

Empire

Hi-Light GLASS CERAMIC HOBS



KCT 4785 Em

Induction INTELLIGENT SYSTEM Touch control
 POWER-SLIDE Safety Guard 45 cm

Anthracite glass ceramic

Design

- Produkt line **Empire**

Controls

- Electronic **Intelligent System** switch with programmer
- **LED** displays
- Child safety lock
- Timer for each cooking zone
- Minute minder



KCT 4785 ElfEm

Induction INTELLIGENT SYSTEM Touch control
 POWER-SLIDE Safety Guard 45 cm

Ivory glass ceramic

Comfort

- **QuickHeat** cooking zones
- Automatic shutdown system **Safety Guard**
- Residual heat indicators
- Shock resistant ceramics, glass with durable graphics
- Easy to clean



KCT 4785 RotEm

Induction INTELLIGENT SYSTEM Touch control
 POWER-SLIDE Safety Guard 45 cm

Bordeaux glass ceramic

Technical specifications

Hi-Light heating elements:

- 1 zone Ø 15,0 cm 1,2 kW
- 1 zones Ø 18,5 cm 1,8 kW
- 1 zone Ø 18,5 / 12,0 cm 2,2 / 1,0 kW
- Total power, kW 5,2
- Net weight, kg 9,0
- Gross weight, kg 11,0

Dimensions (H x W x D, cm)

- Unit dimensions 4,4 x 45,0 x 51,0
- Cut-out 42,0 x 49,0
- Dimensions in packaging 12,5 x 55,0 x 61,5

Empire

GLASS CERAMIC HOBS **Empire** – Induction and Hi-Light

- super-fast heating;
- function **Power** – cooking zones' power ascension;
- various diameters of the heating zones;
- design **Empire** – ceramic surface with front and rear solid metal plates



GAS HOBS



Ergonomically designed, comfortable pan supports are made of high quality cast iron. In both cases, its shape allows for reliable use cookware of any size, even a very large. Pan supports are easy to clean in usual kitchen sink and dishwasher. Pan supports designed and made without sharp corners and it makes them easy to clean.

Stainless steel knobs

Control knobs of all gas hobs are stylish and made of stainless steel, it is same as in many built-in ovens Kaiser, which allows you to create exquisite design of your kitchen, using different elements of our appliances. Besides to the beautiful appearance the knobs are very convenient for the gas adjustment, also it is excellent for cleaning.



GAS HOBS WITH GLASS TOP

Avantgarde PRO



KCG 9387 Turbo

Gas-Control  Ignition by knob 90 cm

Black glass

Design

- Produkt line *Avantgarde*
- Black glass

Controls

- Ergonomic rotary solid metal knobs

Equipment

- Triple ring Turbo burner with quick heating and increased power
- Cast iron pan support
- Cast iron burner caps
- Cast iron Wok adapter
- Additional nozzles for LPG

Comfort

- One-hand ignition in rotary knob
- Flame failure safety device
- Infinitely variable control
- Easy to clean

Technical specifications

Gas heating elements:

- 1 Turbo burner Ø 13,0 cm 3,8 kW
- 1 burner Ø 4,0 cm 1,0 kW
- 2 burners Ø 6,5 cm 1,75 kW
- 1 burner Ø 9,0 cm 3,0 kW
- Net weight, kg 21,0
- Gross weight, kg 23,5

Dimensions (H × W × D, cm)

- Unit dimensions 3,9 × 86,0 × 51,0
- Cut-out 73,0 × 49,0
- Packaging 16,5 × 91,5 × 57,5

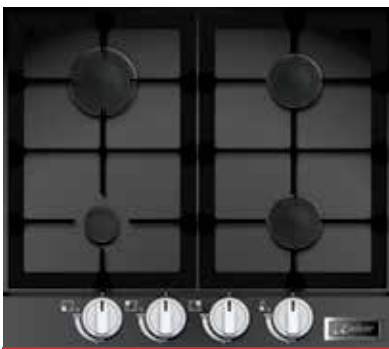

KCG 6387 Turbo

Gas-Control  Ignition by knob 60 cm

Black glass

Design

- Produkt line *Avantgarde*
- Black glass

Controls

- Ergonomic rotary solid metal knobs

Equipment

- Triple ring Turbo burner with quick heating and increased power
- Cast iron pan support
- Cast iron burner caps
- Cast iron Wok adapter
- Additional nozzles for LPG

Comfort

- One-hand ignition in rotary knob
- Flame failure safety device
- Infinitely variable control
- Easy to clean

Technical specifications

Gas heating elements:

- 1 Turbo burner Ø 13,0 cm 3,8 kW
- 1 burner Ø 4,0 cm 1,0 kW
- 2 burners Ø 6,5 cm 1,75 kW
- Net weight, kg 15,0
- Gross weight, kg 16,5

Dimensions (H × W × D, cm)

- Unit dimensions 5,5 × 58,0 × 51,0
- Cut-out 56,0 × 49,0
- Packaging 16,5 × 67,5 × 57,5

Avantgarde PRO

GAS HOBS WITH GLASS TOP

Avantgarde^{PLUS}



KCG 8382 Turbo

Gas-Control  Ignition by knob 77 cm

Black glass with front bevel

Design

- Produkt line *Avantgarde™*

Controls

- Elegant ergonomic rotary metal knobs

Equipment

- Triple ring Turbo burner with quick heating and increased power
- Cast iron pan support
- Cast iron burner caps
- Additional nozzles for LPG
- Cast iron Wok adapter

Comfort

- One-hand ignition in rotary knob
- Flame failure safety device
- Infinitely variable control
- Easy to clean

Technical specifications

Gas heating elements:

- 1 Turbo burner Ø 13,0 cm 3,8 kW
- 1 burner Ø 9,0 cm 3,0 kW
- 1 burner Ø 4,0 cm 1,0 kW
- 2 burners Ø 6,5 cm 1,75 kW
- Gas connection rating, kW 11,3
- Net weight (kg) 18,00
- Gross weight (kg) 20,20

Dimensions (H × W × D, cm)

- Unit dimensions 5,5 × 77,0 × 51,0
- Cut-out 3,0 × 49,0
- Packaging 16,5 × 82,5 × 57,5



KCG 6382 Turbo

Gas-Control  Ignition by knob 60 cm

Black glass with front bevel

Design

- Produkt line *Avantgarde™*

Controls

- Elegant ergonomic rotary metal knobs

Equipment

- Triple ring Turbo burner with quick heating and increased power
- Cast iron pan support
- Cast iron burner caps
- Cast iron Wok adapter
- Additional nozzles for LPG

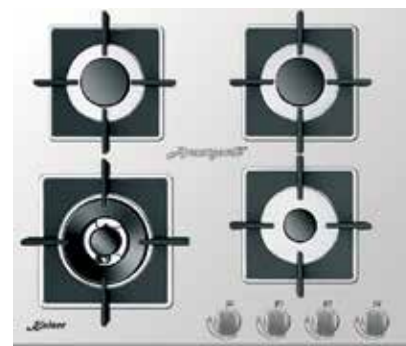

KCG 6382 W Turbo

Gas-Control  Ignition by knob 60 cm

White glass with front bevel

Comfort

- One-hand ignition in rotary knob
- Flame failure safety device
- Infinitely variable control
- Easy to clean

Technical specifications

Gas heating elements:

- 1 Turbo burner Ø 13,0 cm 3,8 kW
- 1 burner Ø 4,0 cm 1,0 kW
- 2 burners Ø 6,5 cm 1,75 kW
- Gas connection rating, kW 8,3
- Net weight (kg) 14,40
- Gross weight (kg) 16,00



Dimensions (H × W × D, cm)

- Unit dimensions 5,5 × 59,0 × 51,0
- Cut-out 56,0 × 49,0
- Packaging 16,5 × 67,5 × 57,5

Avantgarde^{PLUS}

GAS HOBS WITH GLASS TOP

GRAND CHEF



KCG 9386 Turbo

Gas-Control  Ignition by knob 90 cm

Black glass with front INOX plate

Design

- Produkt line GRAND CHEF

Controls

- Ergonomic rotary metal knobs

Equipment

- Triple ring Turbo burner with quick heating and increased power
- Cast iron pan support
- Cast iron burner caps
- Cast iron Wok adapter
- Additional nozzles for LPG

Comfort

- One-hand ignition in rotary knob
- Flame failure safety device
- Infinitely variable control
- Easy to clean

Technical specifications

Gas heating elements:

- 1 Turbo burner Ø 13,0 cm 4,5 kW
- 1 burner Ø 4,0 cm 1,0 kW
- 2 burners Ø 6,5 cm 2,0 kW
- 1 burner Ø 9,0 cm 3,0 kW
- Net weight, kg 21,0
- Gross weight, kg 23,1

Dimensions (H × W × D, cm)

- Unit dimensions 3,9 × 86,0 × 51,0
- Cut-out 73,0 × 49,0
- Packaging 16,5 × 91,5 × 57,5



KCG 6380 Turbo

Gas-Control  Ignition by knob 60 cm

Black glass with front bevel

Design

- Produkt line GRAND CHEF

Controls

- Elegant ergonomic rotary metal knobs

Equipment

- Triple ring Turbo burner with quick heating and increased power
- Cast iron pan support
- Cast iron burner caps
- Cast iron Wok adapter
- Additional nozzles for LPG



KCG 6380 W Turbo

Gas-Control  Ignition by knob 60 cm

White glass with front bevel

Comfort

- One-hand ignition in rotary knob
- Flame failure safety device
- Infinitely variable control
- Easy to clean

Technical specifications

Gas heating elements:

- 1 Turbo burner Ø 13,0 cm 3,8 kW
- 1 burner Ø 4,0 cm 1,0 kW
- 2 burners Ø 6,5 cm 1,75 kW
- Gas connection rating, kW 8,3
- Net weight, kg 14,84
- Gross weight, kg 16,18

Dimensions (H × W × D, cm)

- Unit dimensions 5,5 × 58,0 × 51,0
- Cut-out 56,0 × 47,0
- Packaging 16,5 × 67,5 × 57,5

GRAND CHEF

GAS HOBS WITH GLASS TOP



KCG 6390 Turbo Romb

Gas-Control  Ignition by knob 60 cm

Black glass with front bevel



KCG 6390 W Turbo Romb

Gas-Control  Ignition by knob 60 cm

White glass with front bevel



KCG 6394 Turbo Romb

Gas-Control  Ignition by knob 60 cm

Black glass with front bevel



KCG 6394 W Turbo Romb

Gas-Control  Ignition by knob 60 cm

White glass with front bevel



KCG 6383 Turbo

Gas-Control  Ignition by knob 60 cm

Black glass with front bevel

Design

- Produkt line GRAND CHEF

Controls

- Elegant ergonomic rotary metal knob / INOX

Equipment

- Triple ring Turbo burner with quick heating and increased power
- Cast iron pan support
- Cast iron burner caps
- Cast iron Wok adapter
- Additional nozzles for LPG

Comfort

- One-hand ignition in rotary knob
- Flame failure safety device
- Infinitely variable control
- Easy to clean

GRAND CHEF

Design

- Produkt line GRAND CHEF

Controls

- Elegant ergonomic rotary metal knobs

Equipment

- Triple ring Turbo burner with quick heating and increased power
- Cast iron pan support
- Cast iron burner caps
- Cast iron Wok adapter
- Additional nozzles for LPG

Comfort

- One-hand ignition in rotary knob
- Flame failure safety device
- Infinitely variable control
- Easy to clean

Technical specifications

Gas heating elements:

- 1 Turbo burner Ø 13,0 cm 3,8 kW
- 1 burner Ø 4,0 cm 1,0 kW
- 1 burner Ø 6,5 cm 1,75 kW
- 1 burner Ø 9,0 cm 3,0 kW
- Gas connection rating, kW 9,55
- Net weight, kg 17,10
- Gross weight, kg 18,48

Dimensions (H × W × D, cm)

- Unit dimensions 5,5 × 58,0 × 51,0
- Cut-out 56,0 × 47,0
- Packaging 16,5 × 67,5 × 57,5

Technical specifications

Gas heating elements:

- 1 Turbo burner Ø 13,0 cm 3,8 kW
- 1 burner Ø 4,0 cm 1,0 kW
- 2 burners Ø 6,5 cm 1,75 kW
- Gas connection rating, kW 8,3
- Net weight, kg 14,84
- Gross weight, kg 16,18

Dimensions (H × W × D, cm)

- Unit dimensions 5,5 × 58,0 × 51,0
- Cut-out 56,0 × 47,0
- Packaging 16,5 × 67,5 × 57,5

GRAND CHEF

GAS HOBS WITH GLASS TOP

GRAND CHEF



KCG 4380 Turbo

Gas-Control  Ignition by knob 45 cm

Black glass with front bevel



KCG 4380 W Turbo

Gas-Control  Ignition by knob 45 cm

White glass with front bevel



KCG 4384 Turbo

Gas-Control  Ignition by knob 45 cm

Black glass with front bevel



KCG 4384 W Turbo

Gas-Control  Ignition by knob 45 cm

White glass with front bevel

Design

- Produkt line GRAND CHEF

Controls

- Elegant ergonomic rotary metal knobs

Equipment

- Triple ring Turbo burner with quick heating and increased power
- Cast iron pan support
- Cast iron burner caps
- Cast iron Wok adapter
- Additional nozzles for LPG

Comfort

- One-hand ignition in rotary knob
- Flame failure safety device
- Infinitely variable control
- Easy to clean

Technical specifications

Gas heating elements:

- 1 Turbo burner Ø 13,0 cm 3,8 kW
- 1 burner Ø 4,0 cm 1,0 kW
- 1 burner Ø 6,5 cm 1,75 kW
- Gas connection rating, kW 6,55
- Net weight, kg 12,60
- Gross weight, kg 13,98

Dimensions (H × W × D, cm)

- Unit dimensions 5,5 × 45,0 × 51,0
- Cut-out 43,0 × 49,0
- Packaging 16,5 × 51,5 × 57,5

GRAND CHEF

GAS HOBS WITH GLASS TOP DOMINO



KCG 3382

Gas-Control  Ignition by knob 30 cm

Black glass with front bevel

Design

- Produkt line *Avantgarde*

Controls

- Elegant ergonomic rotary metal knob

Equipment

- Cast iron pan support
- Cast iron burner caps
- Cast iron Wok adapter
- Additional nozzles for LPG

Comfort

- One-hand ignition in rotary knob
- Flame failure safety device
- Infinitely variable control
- Easy to clean

Technical specifications

Gas heating elements:

- 1 burner Ø 4,0 cm 1,0 kW
- 1 burners Ø 9,0 cm 3,0 kW
- Gas connection rating, kW 4,0
- Net weight, kg 7,00
- Gross weight, kg 8,06

Dimensions (H × W × D, cm)

- Unit dimensions 4,0 × 30,0 × 51,0
- Cut-out 28,0 × 49,0
- Packaging 16,5 × 36,5 × 57

Avantgarde PLUS

GAS HOBS WITH GLASS TOP

Empire



KCG 6335 Em Turbo

Gas-Control
Bronze  Ignition
by knob 60 cm

Black glass

Design

- Produkt line **Empire**
- Decor – solid metal **Bronze**

Controls

- Ergonomic rotary metal knobs / **Bronze**

Equipment

- Triple ring Turbo burner with quick heating and increased power
- Cast iron pan support
- Cast iron burner caps
- Cast iron Wok adapter
- Additional nozzles for LPG



KCG 6335 ElfEm Turbo

Gas-Control
Bronze  Ignition
by knob 60 cm

Ivory glass

Comfort

- One-hand ignition in rotary knob
- Flame failure safety device
- Infinitely variable control
- Easy to clean

Technical specifications

Gas heating elements:

- 1 Turbo burner Ø 13,0 cm 3,8 kW
- 1 burner Ø 4,0 cm 1,0 kW
- 2 burners Ø 6,5 cm 1,75 kW
- Gas connection rating 8,3 kW
- Net weight (kg) 17,50
- Gross weight (kg) 19,50



KCG 6335 RotEm Turbo

Gas-Control
Bronze  Ignition
by knob 60 cm

Bordeaux coloured glass

Dimensions (H × W × D, cm)

- Unit dimensions 5,5 × 58,0 × 51,0
- Cut-out 56,0 × 47,0
- Packaging 16,5 × 67,5 × 57,5

Abmessungen (H × B × T, cm)

- Kochfeldmaße 5,5 × 59,0 × 50,0
- Ausschnittmaße 55,0 × 47,0
- Verpackungsmaße 16,5 × 65,0 × 58,0

Empire



GAS HOBS WITH STAINLESS STEEL TOP



GAS HOBS WITH STAINLESS STEEL TOP

Avantgarde PRO



Gas-Control  Ignition by knob 90 cm

Stainless steel with Anti touch-effect

Design

- Produkt line *Avantgarde*

Controls

- Ergonomic rotary metal knobs

Equipment

- Triple ring Turbo burner with quick heating and increased power
- Cast iron pan support
- Cast iron burner caps
- Cast iron Wok adapter
- Additional nozzles for LPG

Comfort

- One-hand ignition in rotary knob
- Flame failure safety device
- Infinitely variable control
- Easy to clean

Technical specifications

Gas heating elements:

- 1 Turbo burner Ø 13,0 cm 3,8 kW
- 1 burner Ø 4,0 cm 1,0 kW
- 2 burners Ø 6,5 cm 1,75 kW
- 1 burner Ø 9,0 cm 3,0 kW
- Net weight, kg 16,0
- Gross weight, kg 18,5

Dimensions

(H × W × D, cm)

- Unit dimensions 3,9 × 86,0 × 51,0
- Cut-out 73,0 × 49,0
- Packaging 16,5 × 91,5 × 57,5



KG 6357 Turbo
Gas-Control  Ignition by knob 60 cm

Stainless steel with Anti touch-effect

Design

- Produkt line *Avantgarde*

Controls

- Ergonomic rotary metal knobs

Equipment

- Triple ring Turbo burner with quick heating and increased power
- Cast iron pan support
- Cast iron burner caps
- Cast iron Wok adapter
- Additional nozzles for LPG

Comfort

- One-hand ignition in rotary knob
- Flame failure safety device
- Infinitely variable control
- Easy to clean

Technical specifications

Gas heating elements:

- 1 Turbo burner Ø 13,0 cm 3,8 kW
- 1 burner Ø 4,0 cm 1,0 kW
- 2 burners Ø 6,5 cm 1,75 kW
- Net weight, kg 12,2
- Gross weight, kg 13,6

Dimensions

(H × W × D, cm)

- Unit dimensions 5,5 × 58,0 × 51,0
- Cut-out 56,0 × 49,0
- Packaging 16,5 × 67,5 × 57,5

Avantgarde PRO

GAS HOBS WITH STAINLESS STEEL TOP

GRAND CHEF



KG 9356 Turbo

Gas-Control  Ignition by knob 90 cm

Stainless steel with Anti touch-effect

Design

- Produkt line GRAND CHEF

Controls

- Ergonomic rotary metal knobs

Equipment

- Triple ring Turbo burner with quick heating and increased power
- Cast iron pan support
- Cast iron burner caps
- Cast iron Wok adapter
- Additional nozzles for LPG

Comfort

- One-hand ignition in rotary knob
- Flame failure safety device
- Infinitely variable control
- Easy to clean

Technical specifications

Gas heating elements:

- 1 Turbo burner Ø 13,0 cm 4,5 kW
- 1 burner Ø 4,0 cm 1,0 kW
- 2 burners Ø 6,5 cm 1,75 kW
- 1 burner Ø 9,0 cm 3,0 kW
- Net weight, kg 17,5
- Gross weight, kg 19,5

Dimensions (H × W × D, cm)

- Kochfeldmaße 3,9 × 86,0 × 51,0
- Ausschnittmaße 73,0 × 49,0
- Verpackungsmaße 16,5 × 91,5 × 57,5



KG 6350 Turbo

Gas-Control  Ignition by knob 60 cm

Stainless steel with Anti touch-effect

Design

- Produkt line GRAND CHEF

Controls

- Elegant ergonomic rotary metal knobs

Equipment

- Triple ring Turbo burner with quick heating and increased power
- Cast iron pan support
- Cast iron burner caps
- Cast iron Wok adapter
- Additional nozzles for LPG

Technical specifications

Gas heating elements:

- 1 Turbo burner Ø 13,0 cm 3,8 kW
- 1 burner Ø 4,0 cm 1,0 kW
- 2 burners Ø 6,5 cm 1,75 kW
- Gas connection rating, kW 8,3
- Net weight, kg 14,34
- Gross weight, kg 15,72

Dimensions (H × W × D, cm)

- Unit dimensions 5,5 × 58,0 × 51,0
- Cut-out 56,0 × 49,0
- Packaging 16,5 × 67,5 × 57,5

Comfort

- One-hand ignition in rotary knob
- Flame failure safety device
- Infinitely variable control
- Easy to clean



KG 6360 Turbo Romb

Gas-Control  Ignition by knob 60 cm

Stainless steel with Anti touch-effect



KG 6364 Turbo Romb

Gas-Control  Ignition by knob 60 cm

Stainless steel with Anti touch-effect

Design

- Produkt line GRAND CHEF

Controls

- Elegant ergonomic rotary metal knobs

Equipment

- Triple ring Turbo burner with quick heating and increased power
- Cast iron pan support
- Cast iron burner caps
- Cast iron Wok adapter
- Additional nozzles for LPG

Comfort

- One-hand ignition in rotary knob
- Flame failure safety device
- Infinitely variable control
- Easy to clean

Technical specifications

Gas heating elements:

- 1 Turbo burner Ø 13,0 cm 3,8 kW
- 1 burner Ø 4,0 cm 1,0 kW
- 1 burner Ø 6,5 cm 1,75 kW
- 1 burner Ø 9,0 cm 3,0 kW
- Gas connection rating, kW 9,55
- Net weight, kg 16,85
- Gross weight, kg 18,20

Dimensions (H × W × D, cm)

- Unit dimensions 5,5 × 60,0 × 51,0
- Cut-out 55,0 × 47,0
- Packaging 16,5 × 67,5 × 58,0

GRAND CHEF

GAS HOBS WITH STAINLESS STEEL TOP

Grand CHEF



KG 4350 Turbo

Gas-Control  Ignition by knob 45 cm

Stainless steel with Anti touch-effect

Design

- Produkt line GRAND CHEF

Controls

- Ergonomic rotary metal knobs

Equipment

- Triple ring Turbo burner with quick heating and increased power
- Cast iron pan support
- Cast iron burner caps
- Cast iron Wok adapter
- Additional nozzles for LPG



KG 4354 Turbo

Gas-Control  Ignition by knob 45 cm

Stainless steel with Anti touch-effect

Comfort

- One-hand ignition in rotary knob
- Flame failure safety device
- Infinitely variable control
- Easy to clean

Technical specifications

Gas heating elements:

- 1 Turbo burner Ø 13,0 cm 3,8 kW
- 1 burner Ø 4,0 cm 1,0 kW
- 1 burner Ø 6,5 cm 1,75 kW
- Gas connection rating, kW 6,55
- Net weight, kg 12,2
- Gross weight, kg 13,6

Dimensions (H × W × D, cm)

- Unit dimensions 5,5 × 45,0 × 51,0
- Cut-out 43,0 × 49,0
- Packaging 16,5 × 51,5 × 57,5

GAS HOBS WITH STAINLESS STEEL TOP **DOMINO**



KG 3351

Gas-Control  Ignition by knob 30 cm

Stainless steel with Anti touch-effect

Design

- Produkt line GRAND CHEF
- Stainless steel with **Anti touch**-effect

Controls

- Elegant ergonomic rotary metal knobs

Equipment

- Cast iron pan support
- Cast iron burner caps
- Additional nozzles for LPG

Comfort

- One-hand ignition in rotary knob
- Flame failure safety device
- Infinitely variable control
- Easy to clean

Technical specifications

Gas heating elements:

- 1 burner Ø 4,0 cm 1,0 kW
- 2 burners Ø 9,0 cm 3,0 kW
- Gas connection rating, kW 4,0
- Net weight, kg 6,08
- Gross weight, kg 7,12

Dimensions (H × W × D, cm)

- Unit dimensions 5,5 × 30,0 × 51,0
- Cut-out 28,0 × 49,0
- Packaging 16,5 × 36,5 × 57,5

Grand CHEF

GAS HOBS WITH ENAMELED TOP

Empire



KG 9325 Em Turbo

Gas-Control Ignition by knob 90 cm Bronze

Anthracite colored enamel

Design

- Product line **Empire**
- Decor – solid metal **Bronze**

Controls

- Ergonomic rotary metal knobs / **Bronze**

Equipment

- Triple ring Turbo burner with quick heating and increased power
- Cast iron pan support
- Cast iron burner caps
- Cast iron Wok adapter
- Additional nozzles for LPG



KG 9325 ElfEm Turbo

Gas-Control Ignition by knob 90 cm Bronze

Ivory colored enamel

Comfort

- One-hand ignition in rotary knob
- Flame failure safety device
- Infinitely variable control
- Easy to clean

Technical specifications

Gas heating elements:

- 1 Turbo burner Ø 13,0 cm 3,8 kW
- 1 burner Ø 9,0 cm 3,0 kW
- 1 burner Ø 4,0 cm 1,0 kW
- 2 burners Ø 6,5 cm 1,75 kW
- Gas connection rating 11,3 kW
- Net weight (kg) 15,00
- Gross weight (kg) 17,00

Dimensions (H × W × D, cm)

- Unit dimensions 5,5 × 86,0 × 50,0
- Cut-out 75,0 × 47,0
- Packaging 16,5 × 91,5 × 58,0



KG 6325 Em Turbo

Gas-Control Ignition by knob 60 cm Bronze

Anthracite colored enamel

Design

- Product line **Empire**
- Decor – solid metal **Bronze**

Controls

- Ergonomic rotary metal knobs / **Bronze**

Equipment

- Triple ring Turbo burner with quick heating and increased power
- Cast iron pan support
- Cast iron burner caps
- Cast iron Wok adapter
- Additional nozzles for LPG



KG 6325 ElfEm Turbo

Gas-Control Ignition by knob 60 cm Bronze

Ivory colored enamel

Comfort

- One-hand ignition in rotary knob
- Flame failure safety device
- Infinitely variable control
- Easy to clean

Technical specifications

Gas heating elements:

- 1 Turbo burner Ø 13,0 cm 3,8 kW
- 1 burner Ø 4,0 cm 1,0 kW
- 2 burners Ø 6,5 cm 1,75 kW
- Gas connection rating 8,3 kW
- Net weight (kg) 11,50
- Gross weight (kg) 13,50

Dimensions (H × W × D, cm)

- Unit dimensions 5,5 × 59,0 × 50,0
- Cut-out 55,0 × 47,0
- Packaging 16,5 × 65,0 × 58,0

Empire





Cookers



ELECTRIC COOKERS WITH INDUCTION COOKTOP

Empire



HC 93655 IEm

Induction Teleskop Bronze

Safety Guard 90 cm

Anthracite coloured enamel

Design

- Produkt line **Empire**
- Enameled metal door and control panel in colors: Anthracite, Ivory, Bordeaux
- Analog clock
- Elegant massive metal door handle **Bronze**
- Panoramic inner glass with recipe table

Features

- Tangential circulation system
- Turnable rotisserie with chromed frame and removable handle
- Shelf support chromed rails
- Telescopic extension system **Teleskop** – 1 level, optional up to 3 levels
- 5 Rack levels

Equipment

- 1 enamelled baking tray
- 1 enamelled baking pan
- 1 multifunction roast shelf
- 1 chromed handle for Trays



HC 93655 IEIfEm

Induction Teleskop Bronze

Safety Guard 90 cm

Ivory coloured enamel

Control

- Analogue control
- Electromechanical programmer with metal rotary knobs
- Elegant ergonomic metal knobs **Bronze**
- Child safety lock

Comfort

- **FREE ZONE** – Heating the dishes of any size over the entire area of the heating zone
- Booster function **Power** for all cooking zones
- Induction cooking zones, self-adjustable according to size of an utensil
- Automatic shutdown system **Safety Guard**
- Residual heat indicators
- Shock resistant ceramics, glass with durable graphics
- Easy to clean

Multifunctional electric oven **Multi 8**

- **7 heating modes**
 - **1 defrosting mode**
 - Easy-clean anti-allergic enamel
 - Cold front — **3 glasses** oven door
 - Special thermo-reflective glass
- THERMO-REFLECTIVE**



HC 93655 IRotEm

Induction Teleskop Bronze

Safety Guard 90 cm

Bordeaux coloured enamel

Technical specifications

Induction hob cooking zones (**Power**-function):

- 4 zones 21,0 × 21,0 cm 1,8 kW (2,1 kW)
- 2 zones 40,0 × 22,0 cm 3,0 kW (3,6 kW)
- 1 zone Ø 28,0 cm 3,0 kW (4,0 kW)
- Oven energy efficiency **A**
- Gross capacity, L. 115,0
- Net capacity according to EU standards, L 103,0
- Total power, kW 13,6
- Net weight, kg 80,0
- Gross weight, kg 90,0

Dimensions (H × W × D, cm)

- Cooker dimensions 90,0 × 90,0 × 60,0
- Dimensions in packaging 102,0 × 93,0 × 70,5

FREE ZONE
Power INDUCTION

Empire

ELECTRIC COOKERS WITH INDUCTION COOKTOP

Avantgarde PRO



**4 x 4
FREE ZONE
Power INDUCTION**

HC 93690 IR

Induction Safety Guard Teleskop

POWER-SLIDE

90 cm

**Stainless steel INOX with
Anti touch effect**

Design

- Produkt line *Avantgarde*
- Moire glass ceramic
- Elegant solid metal door handle
- Panoramic inner glass with recipe table

Features

- Tangential circulation system
- Shelf support chromed rails
- 5 Rack levels
- Telescopic extension system **Teleskop** – 2-fold used in every level, optional up to 3-fold

Equipment

- 2 enamelled trays with Easy-clean enamel
- 1 multifunction chromed roast shelf
- 1 chromed handle for trays

Control

- Electronic **Intelligent System** switch with programmer
- Induction - Cooking zone control **Power Slide**
- Oven - Electronic **TFT** Touchscreen full sensor control

HC 93690 IS

Induction Safety Guard Teleskop

POWER-SLIDE

90 cm

Black steel

Comfort

- **FREE ZONE** – Heating the dishes of any size over the entire area of the heating zone
- **Teppan Yaki** – Heating the dishes of any size over the entire area of the heating zone
- **4x4** - optimal use of whole heating area
- Booster function **Power** for all cooking zones
- Induction cooking zones, self-adjustable according to size of an utensil
- Automatic shutdown system **Safety Guard**
- Residual heat indicators
- Shock resistant ceramics, glass with durable graphics
- Easy to clean
- Multi 22 Multifunctional electric oven (top and bottom heat, hot air system, infrared grill – 10 operating modes)
- Catalytic enamel inserts
- **Easy-clean** enamel
- Cold front – 3 glasses oven door
- Special **THERMO-REFLECTIVE** glass

Technical specifications

Induction hob cooking zones (**Power**-function):

- 4 zones 20,0 × 22,0 cm 2,0 kW (3,0 kW)
- 2 zones 40,0 × 20,0 cm 3,0 kW (3,6 kW)
- 1zone 40,0 × 44,0 cm 4,8 kW (5,6 kW)
- 2 zones 28,0 × 20,0 cm 2,0 kW (3,0 kW)
- 1 zone 28,0 × 40,0 cm 3,0 kW (3,6 kW)
- Oven energy efficiency A
- Gross capacity, L. 115,0
- Net capacity according to EU standards, L 103,0
- Total power, kW 14,2
- Net weight, kg 80,0
- Gross weight, kg 90,0

Dimensions (H × W × D, cm)

- Cooker dimensions 90,0 × 90,0 × 60,0
- Dimensions in packaging 102,0 × 93,0 × 70,5



Avantgarde PRO

ELECTRIC COOKERS WITH INDUCTION COOKTOP

Avantgarde PRO



HC 93691 IR

Induction Safety Guard Teleskop

90 cm

Stainless steel INOX with Anti touch effect

Design

- Produkt line Avantgarde[®]
- Stainless steel with **Anti touch**-effect
- Elegant solid metal door handle
- Panoramic inner glass with recipe table

Features

- Tangentiale Zirkulationssystem
- Verchromte Einschubgitter
- 5 Einschubebenen
- Teleskopauszugssystem **Teleskop** – 2-fach in jeder Ebene einsetzbar, optional bis 3-fach

Equipment

- 2 enamelled trays with Easy-clean antiallergic enamel
- 1 multifunction chromed roast shelf
- 1 chromed handle for trays

Control

- Electronic sensor-controlled programmer **Intelligent System** with program function
- Induction - cooking zone control Power Slide
- Oven - Electronic sensor-controlled programmer **Touch control** with solid metal rotary knobs INOX
- Multifunction **LED**-display



HC 93691 IS

Induction Safety Guard Teleskop

90 cm

Black steel

Comfort

- **FREE ZONE** – Heating the dishes of any size over the entire area of the heating zone
- Booster function **Power** for all cooking zones
- Induction cooking zones, self-adjustable according to size of an utensil
- Automatic shutdown system **Safety Guard**
- Residual heat indicators
- Shock resistant ceramics, glass with durable graphics
- Easy to clean
- **Multi 8** Multifunctional electric oven (top and bottom heat, hot air system, infrared grill – 8 operating modes)
- Catalytic enamel inserts
- **Easy-clean** antiallergic enamel
- Cold front – **3 glasses** oven door
- Special **THERMO-REFLECTIVE** glass

Technical specifications

Induction hob cooking zones (**Power**-function):

- 4 zones 21,0 × 21,0 cm 1,8 (2,1 kW)
- 2 zones 40,0 × 22,0 cm 3,0 kW (3,6 kW)
- 1 zone Ø 28,0 cm 2,0 (4,0 kW)
- Oven energy efficiency **A**
- Gross capacity, L. 115,0
- Net capacity according to EU standards, L. 103,0
- Total power, kW 13,6
- Net weight, kg 80,0
- Gross weight, kg 90,0

Dimensions (H × W × D, cm)

- Herdemaße 90,0 × 90,0 × 60,0
- Verpackungsmaße 102,0 × 93,0 × 70,5

FREE ZONE
Power INDUCTION

Avantgarde PRO



HGE 93555 Em

Gas-Control Teleskop  **Ignition by knob** 90 cm
Bronze

Anthracite coloured enamel

Design

- Produkt line **Empire**
- Electric cooker with gas cooktop
- Decorative parts - solid metal **Bronze**
- Elegant solid metal door handle **Bronze**

Features

- Tangential circulation system
- 2 Circulation fans
- Turnable rotisserie with chromed frame and removable handle
- Shelf support chromed rails
- 5 Rack levels
- Telescopic extension system **Teleskop** – 1-fold used in every level, optional up to 3-fold

Equipment

- 1 enamelled tray with **Easy-clean** enamel
- 1 multifunction chromed roast shelf
- 1 chromed handle for trays
- Triple ring Turbo burner with quick heating and increased power
- Cast iron pan support
- Cast iron burner caps
- Cast iron Wok adapter
- Additional nozzles for LPG



HGE 93555 ElfEm

Gas-Control Teleskop  **Ignition by knob** 90 cm
Bronze

Ivory coloured enamel

Control

- Electromechanical programmer with metal rotary knobs **Bronze**
- Electronic-analogue timer with alarm and child lock function

Comfort

- Multi 8 Multifunctional electric oven (top and bottom heat, hot air system, infrared grill – 8 operating modes)
- Catalytic enamel inserts
- **Easy-clean** enamel
- Cold front – **3 glasses** oven door
- Special **THERMO-REFLECTIVE** glass
- One-hand ignition in rotary knob
- Flame failure safety device
- Infinitely variable control
- Easy to clean



HGE 93555 RotEm

Gas-Control Teleskop  **Ignition by knob** 90 cm
Bronze

Bordeaux coloured enamel

Technical specifications

- Energy efficiency class **A**
- Gross capacity, L. 115,0
- Net capacity according to EU standards, L 103,0
- 1 Turbo burner Ø 13,0 cm 3,8 kW
- 1 burner Ø 4,0 cm 1,0 kW
- 2 burners Ø 6,5 cm 1,75 kW
- 1 burner Ø 9,0 cm 3,0 kW
- Total power, kW 13,6
- Net weight, kg 80,0
- Gross weight, kg 90,0

Dimensions (H × W × D, cm)

- Cooker dimensions 90,0 × 90,0 × 60,0
- Dimensions in packaging 102,0 × 93,0 × 70,5



ELECTRIC COOKER WITH GAS COOKTOP *Avantgarde* PRO



HGE 93505 R

Gas-Control Teleskop  Ignition by knob 90 cm

Stainless steel INOX with Anti touch effect

Design

- Produkt line *Avantgarde*
- Elegant solid metal door handle
- Panoramic inner glass with recipe table

Features

- Tangential circulation system
- 2 Circulation fans
- Turnable rotisserie with chromed frame and removable handle
- Shelf support chromed rails
- 5 Rack levels
- Telescopic extension system **Teleskop** – 1-fold used in every level, optional up to 3-fold

Equipment

- 1 enamelled tray with **Easy-clean** enamel
- 1 multifunction chromed roast shelf
- 1 chromed handle for trays
- Triple ring Turbo burner with quick heating and increased power
- Cast iron pan support
- Cast iron burner caps
- Cast iron Wok adapter
- Additional nozzles for LPG



HGE 93505 S

Gas-Control Teleskop  Ignition by knob 90 cm

Black with INOX Anti touch effect

Control

- Electronic sensor-controlled programmer **Intelligent System** with metal rotary knobs
- Electronic sensor-controlled programmer **Touch control**
- Multifunction **LED**-display

Comfort

- **Multi 8** Multifunctional electric oven (top and bottom heat, hot air system, infrared grill – 8 operating modes)
- Catalytic enamel inserts
- **Easy-clean** enamel
- Cold front – **3 glasses** oven door
- Special **THERMO-REFLECTIVE** glass
- One-hand ignition in rotary knob
- Flame failure safety device
- Infinitely variable control
- Easy to clean

Technical specifications

- Energy efficiency class **A**
- Gross capacity, L 115,0
- Net capacity according to EU standards, L 103,0
- 1 Turbo burner Ø 13,0 cm 3,8 kW
- 1 burner Ø 4,0 cm 1,0 kW
- 2 burners Ø 6,5 cm 1,75 kW
- 1 burner Ø 9,0 cm 3,0 kW
- Total power, kW 3,5
- Net weight, kg 60,0
- Gross weight, kg 70,0

Dimensions (H × W × D cm)

- Cooker dimensions 90,0 × 90,0 × 60,0
- Dimensions in packaging 102,0 × 93,0 × 70,5



HGG 93405 R

Gas-Control Teleskop  Ignition by knob 90 cm

Stainless steel INOX with Anti touch effect

Design

- Produkt line *Avantgarde*
- Elegant solid metal door handle
- Panoramic inner glass with recipe table

Features

- Tangential circulation system
- Circulation fan
- Turnable rotisserie with chromed frame and removable handle
- Shelf support chromed rails
- 5 Rack levels
- Telescopic extension system **Teleskop** – 1-fold used in every level, optional up to 3-fold

Equipment

- 1 enamelled tray with **Easy-clean** enamel
- 1 multifunction chromed roast shelf
- 1 chromed handle for trays
- Triple ring Turbo burner with quick heating and increased power
- Cast iron pan support
- Cast iron burner caps
- Cast iron Wok adapter
- Additional nozzles for LPG



HGG 93405 S

Gas-Control Teleskop  Ignition by knob 90 cm

Black with INOX Anti touch effect

Control

- Electronic sensor-controlled programmer **Intelligent System** with metal rotary knobs
- Electronic sensor-controlled programmer **Touch control**
- Multifunction **LED**-display

Comfort

- **XXL** Multifunctional gas cooker with fan, bottom heat, infrared grill
- Catalytic enamel inserts
- Easy-clean enamel
- Cold front – 3 glasses oven door
- Special THERMO-REFLECTIVE glass
- One-hand ignition in rotary knob
- Flame failure safety device
- Infinitely variable control
- Easy to clean

Technical specifications

- Energy efficiency class **A**
- Gross capacity, L. 115,0
- Net capacity according to EU standards, L 103,0
- 1 Turbo burner Ø 13,0 cm 3,8 kW
- 1 burner Ø 4,0 cm 1,0 kW
- 2 burners Ø 6,5 cm 1,75 kW
- 1 burner Ø 9,0 cm 3,0 kW
- Net weight, kg 60,0
- Gross weight, kg 70,0

Dimensions (H × W × D, cm)

- Cooker dimensions 90,0 × 90,0 × 60,0
- Dimensions in packaging 102,0 × 93,0 × 70,5

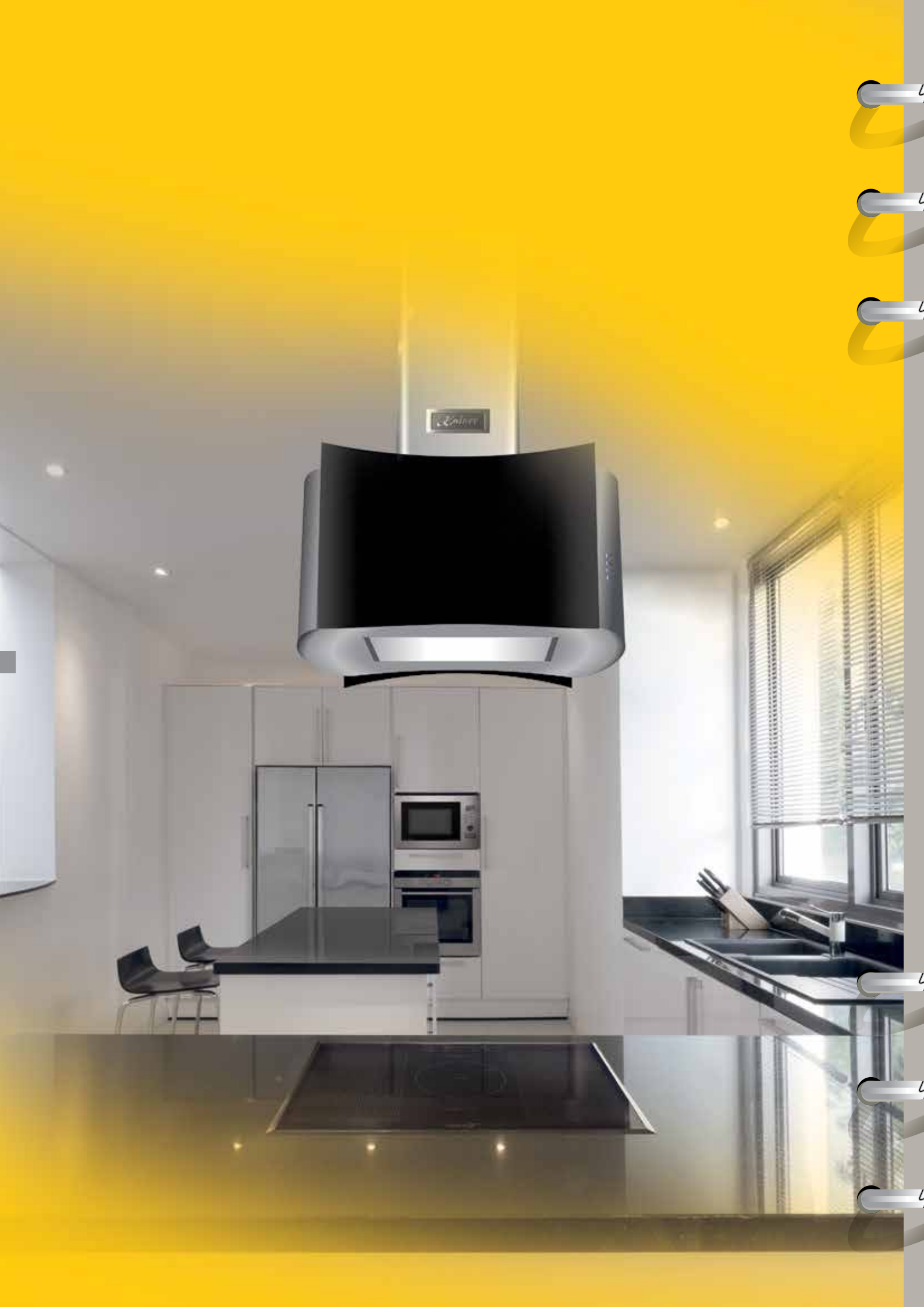

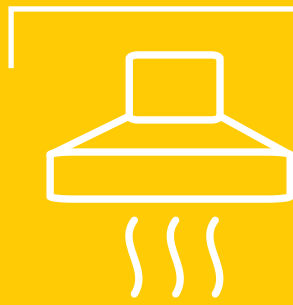

Cooker hoods

COOKER HOODS

In certain cases chimney hoods can't be optimally adapted to the kitchen design. If you consider having a built-in hood *Kaiser*, the air will be fresh and clean and design of your kitchen remains without modification. You get cooker hood, as well as an illumination source.

When pulling out the front panel, the lighting is switched on and you have to adjust only the speed you need.

Each cooker hood has carbon filters to neutralize odours, and metal grease filters, which are suitable for washing in dishwasher.

The keys with lighting allow, depends of the food you cook, to switch the light on and off and choose suction power.

Thanks to modern high-performance engines and improved noise insulation built-in cooker hoods Kaiser are excellent for use as air filter. Front panels in stainless steel with anti-touch effect offer the possibility to make the kitchen styling according to your wishes.



Built-in cooker hoods open automatically when you pull out front panel and closes after operation finish. The display shows you when to replace or clean the filter.

The electronic control for **LED** lighting makes the operation of cooker hood effortless and easy.

WALL-MOUNTED COOKER HOODS



AT 9317

INTELLIGENT SYSTEM **Full touch** **INOX Anti touch** **LED**

◀ 90 cm ▶

Black glass / INOX frame
Automatic opening

Design

- Product line *La Perle*

Features

- 1 Metal grease filters
- 2 charcoal filters
- Light - **LED**, 2 × 1,5 W

Equipment

- Pipe adapter 150-120 mm
- Aluminium pipe

Control

- Electronic controlled programmer **Intelligent System**
- Electronic full sensor control **Full Touch**
- Multilingual **TFT** touch screen display

Comfort

- Timer
- Lighting, independent of cooker hood
- Perimeter suction
- Low noise
- Dishwasher-suitable grease filters

Technical specifications

	B
• Energy efficiency class	1200
• Suction power, m ³ /h	1
• Motors	5
• Speeds	Exhaust/ Recirculation
• Operation mode	120/ 150
• Output hole size (mm)	28,5
• Net weight, kg	33,5
• Gross weight, kg	

Dimensions (H × B × T, cm)

• Unit dimensions	89,0 × 90,0 × 40,8
• Dimensions in packaging	57,5 × 97,0 × 67,5

La Perle



AT 9440 Eco

INTELLIGENT SYSTEM **Full touch** **INOX Anti touch** **LED**

◀ 90 cm ▶

Black glass / INOX frame
Automatic opening

Design

- Product line *Avantgarde*

Features

- 1 Metal grease filters
- 2 charcoal filters
- Light – **LED**, 2 × 1,5 W

Equipment

- Pipe adapter 150-120 mm
- Aluminium pipe

Control

- Electronic full sensor control with programmer **Intelligent System**
- **LED** indication

Comfort

- Automatic opening
- Timer
- Lighting, independent of cooker hood
- Low noise
- Dishwasher-suitable grease filters

Technical specifications

	A
• Energy efficiency class	1250
• Suction power, m ³ /h	1
• Motors	5
• Speeds	Exhaust/ Recirculation
• Operation mode	120/ 150
• Output hole size (mm)	30,8
• Net weight, kg	35,8
• Gross weight, kg	

Dimensions (H × B × T, cm)

• Unit dimensions	89,0 × 90,0 × 40,8
• Dimensions in packaging	57,5 × 97,0 × 67,5



AT 6433 Eco

INTELLIGENT SYSTEM **Full touch** **INOX Anti touch** **LED**

◀ 60 cm ▶

Black glass/ Stainless steel with Anti touch effect

Design

- Product line *Avantgarde*

Features

- 1 Metal grease filters
- 2 charcoal filters
- Light panel – **LED**, 1 × 16,0 W

Equipment

- Pipe adapter 150-120 mm
- Aluminium pipe

Control

- Electronic full sensor control with programmer **Intelligent System**
- **LED** indication

Comfort

- Timer
- Perimeter suction
- Light panel
- Lighting, independent of cooker hood
- Low noise
- Dishwasher-suitable grease filters

Technical specifications

	A
• Energy efficiency class	1250
• Suction power, m ³ /h	1
• Motors	3
• Speeds	Exhaust/ Recirculation
• Operation mode	120/ 150
• Output hole size (mm)	18,0
• Net weight, kg	21,0
• Gross weight, kg	

Dimensions (H × B × T, cm)

• Unit dimensions	56,0 × 60,0 × 50,0
• Dimensions in packaging	66,0 × 41,0 × 57,0

Avantgarde PRO

WALL-MOUNTED COOKER HOODS

Avantgarde **PRO**



AT 9455 N Eco

INTELLIGENT SYSTEM **INOX** Anti touch **LED**

◀ 90 cm ▶

Stainless steel with Anti-touch effect

Design

- Product line *Avantgarde*

Features

- 3 Metal grease filters
- 2 charcoal filters
- Light – **LED**, 2 × 2,5 W



AT 9455 N S Eco

INTELLIGENT SYSTEM **INOX** Anti touch **LED**

◀ 90 cm ▶

Blued black steel with Anti-touch effect

Equipment

- Pipe adapter 150-120 mm
- Aluminium pipe

Control

- Electronic full sensor Metal Touch **control** with programmer **Intelligent System**
- **LED** indication

Comfort

- Timer
- Lighting, independent of cooker hood
- Perimeter suction
- Low noise
- Dishwasher-suitable grease filters

Technical specifications

• Energy efficiency class	A
• Suction power, m ³ /h	1250
• Motors	1
• Speeds	3
• Operation mode	Exhaust/ Recirculation
• Output hole size (mm)	120/ 150
• Net weight, kg	21,9
• Gross weight, kg	23,9

Dimensions (H × B × T, cm)

- Unit dimensions 88,8 × 90,0 × 46,5
- Dimensions in packaging 56,5 × 98,0 × 46,0



AT 6450 N Eco
AT 9450 N Eco

INTELLIGENT SYSTEM **INOX** Anti touch **LED**

◀ 60 cm / 90 cm ▶

Black matt / stainless steel with Anti-touch effect

Design

- Product line *Avantgarde*

Features

- 2 Metal grease filters
- 2 charcoal filters
- Light – **LED**, 2 × 2,5 W

Equipment

- Pipe adapter 150-120 mm
- Aluminium pipe

Control

- Electronic full sensor Metal Touch **control** with programmer **Intelligent System**
- **LED** indication

Technical specifications

• Energy efficiency class	A
• Suction power, m ³ /h	1250
• Motors	1
• Speeds	3
• Operation mode	Exhaust/ Recirculation
• Output hole size (mm)	120/ 150

AT 6450 N Eco

- Net weight, kg 16,0
- Gross weight, kg 18,0

AT 9450 N Eco

- Net weight, kg 23,0
- Gross weight, kg 25,0

Dimensions (H × B × T, cm)

- Unit dimensions 75,5 × 60,0 × 44,5
- Dimensions in packaging 71,0 × 65,5 × 52,5

AT 9450 N Eco

- Unit dimensions 115,0 × 90,0 × 44,5
- Dimensions in packaging 91,0 × 65,5 × 52,5

Avantgarde **PRO**

WALL-MOUNTED COOKER HOODS

Avantgarde **PRO**



AT 6430 F Eco
AT 9430 F Eco

INTELLIGENT SYSTEM **INOX Anti touch** **Full touch** **LED**

◀ 60 cm / 90 cm ▶

Black glass with bevels

Design

- Product line *Avantgarde*

Features

- 2 Metal grease filters
- 2 charcoal filters
- Light – **LED**, 2 × 2,5 W



AT 6430 FG Eco
AT 9430 FG Eco

INTELLIGENT SYSTEM **INOX Anti touch** **Full touch** **LED**

◀ 60 cm / 90 cm ▶

Gray glass with bevels

Equipment

- Pipe adapter 150-120 mm
- Aluminium pipe

Control

- Electronic full sensor control with programmer **Intelligent System**
- **LED** indication

Comfort

- Timer
- Lighting, independent of cooker hood
- Perimeter suction
- Low noise
- Dishwasher-suitable grease filters

Technical specifications

- Energy efficiency class **A**
- Suction power, m³/h 1250
- Motors 1
- Speeds 3
- Operation mode Exhaust/ Recirculation
- Output hole size (mm) 120/ 150

AT 6430 F* Eco

- Net weight, kg 16,6
- Gross weight, kg 20,2

AT 9430 F* Eco

- Net weight, kg 18,5
- Gross weight, kg 22,0

Dimensions (H × B × T, cm)

AT 6430 F* Eco

- Unit dimensions 78,8 × 60,0 × 48,0
- Dimensions in packaging 50,5 × 71,0 × 56,0

AT 9430 F* Eco

- Unit dimensions 78,8 × 90,0 × 48,0
- Dimensions in packaging 57,0 × 95,5 × 46,0



AT 6488 Eco

INTELLIGENT SYSTEM **Full touch** **INOX Anti touch**

LED **Touch Free**

◀ 60 cm ▶

Black rounded glass Hands-free automatic opening

Design

- Product line *Avantgarde*
- Black Glass

Features

- 1 Metal grease filters
- 2 charcoal filters
- Light – **LED**, 2 × 1,5 W

Equipment

- Pipe adapter 150-120 mm
- Aluminium pipe

Control

- Electronic full sensor control with programmer **Intelligent System**
- **LED** indication

Comfort

- Timer
- **Hands-free** control
- Lighting, independent of cooker hood
- Low noise
- Dishwasher-suitable grease filters

Technical specifications

- Energy efficiency class **A**
- Suction power, m³/h 1250
- Motors 1
- Speeds 3
- Operation mode Exhaust/ Recirculation
- Output hole size (mm) 120/ 150
- Net weight, kg 17,0
- Gross weight, kg 21,0

Dimensions (H × B × T, cm)

- Unit dimensions 88,0 × 60,0 × 44,0
- Dimensions in packaging 69,0 × 68,0 × 48,0

WALL-MOUNTED COOKER HOODS

Avantgarde **PRO**



AT 5435 Eco
AT 7435 Eco
AT 8435 Eco

INTELLIGENT SYSTEM **Full touch** **INOX Anti touch** **LED**

◀ 50 cm / 70 cm / 80 cm ▶

Black glass / Stainless steel with Anti touch effect

Design

- Product line *Avantgarde*

Features

- 1 Metal grease filters
- 2 charcoal filters
- Light – **LED**, 2 × 2,5 W

Equipment

- Pipe adapter 150-120 mm
- Aluminium pipe

Control

- Electronic full sensor control with programmer **Intelligent System**
- LED** indication

Comfort

- Timer
- Lighting, independent of cooker hood
- Perimeter suction
- Low noise
- Dishwasher-suitable grease filters

Technical specifications

- Energy efficiency class **A**
- Suction power, m³/h 1250
- Motors 1
- Speeds 3
- Operation mode Exhaust/ Recirculation
- Output hole size (mm) 120/ 150

AT 5435 Eco

- Net weight, kg 10,6
- Gross weight, kg 14,2

AT 7435 Eco

- Net weight, kg 13,4
- Gross weight, kg 17,4

AT 8435 Eco

- Net weight, kg 11,8
- Gross weight, kg 14,8

Dimensions (H × B × T, cm)

AT 6410 F Eco

- Unit dimensions 75,5 × 50,0 × 37,5
- Dimensions in packaging 43,5 × 61,0 × 46,0

AT 7435 Eco

- Unit dimensions 75,0 × 70,0 × 37,5
- Dimensions in packaging 43,5 × 83,0 × 46,0

AT 8435 Eco

- Unit dimensions 75,5 × 80,0 × 37,5
- Dimensions in packaging 43,5 × 91,0 × 46,0



AT 6410 F Eco
AT 7410 F Eco

INTELLIGENT SYSTEM **Full touch** **INOX Anti touch** **LED**

◀ 60 cm / 70 cm ▶

Black glass with bevels



AT 6410 FR Eco
AT 7410 FR Eco

INTELLIGENT SYSTEM **Full touch** **INOX Anti touch** **LED**

◀ 60 cm / 70 cm ▶

Black glass with bevels/ Stainless steel with Anti touch effect

Design

- Product line *Avantgarde*
- Chimney hood

Features

- 1 Metal grease filters
- 2 charcoal filters
- Light – **LED**, 2 × 2,0 W

Equipment

- Pipe adapter 150-120 mm
- Aluminium pipe

Control

- Electronic full sensor control with programmer **Intelligent System**
- LED** indication

Comfort

- Timer
- Lighting, independent of cooker hood
- Perimeter suction
- Low noise
- Dishwasher-suitable grease filters

Technical specifications

- Energy efficiency class **A**
- Suction power, m³/h 1250
- Motors 1
- Speeds 3
- Operation mode Exhaust/ Recirculation
- Output hole size (mm) 120/ 150

AT 6410 F Eco

- Net weight, kg 11,5
- Gross weight, kg 14,5

AT 7410 F Eco

- Net weight, kg 11,8
- Gross weight, kg 14,8

Dimensions (H × B × T, cm)

AT 6410 F Eco

- Unit dimensions 77,0 × 60,0 × 37,5
- Dimensions in packaging 43,5 × 65,0 × 44,0

AT 7410 F Eco

- Unit dimensions 77,0 × 70,0 × 37,5
- Dimensions in packaging 43,5 × 75,0 × 44,0

Avantgarde **PRO**

WALL-MOUNTED COOKER HOODS

Avantgarde^{PLUS}



AT 6407 N F
AT 9407 N F

Logic control INOX Anti touch Full touch LED

◀ 60 cm / 90 cm ▶

Black glass with bevels

Design

- Product line *Avantgarde^{PLUS}*
- Stainless steel with **Anti-Touch** effect

Features

- 1 Metal grease filters for 60 cm model, 2 for 90 cm model
- 2 charcoal filters
- Light - **LED**, 2 × 1 W



AT 6407 N FW
AT 9407 N FW

Logic control INOX Anti touch Full touch LED

◀ 60 cm / 90 cm ▶

White glass with bevels

Equipment

- Pipe adapter 150-120 mm
- Aluminium pipe

Control

- Electronic controlled programmer
- Logic control**
- Electronic full sensor control with programmer
- Full Touch**
- LED** Display

Comfort

- Timer
- Lighting, independent of cooker hood
- Perimeter suction
- Low noise
- Dishwasher-suitable grease filters

Technical specifications

Energy efficiency class	B
Suction power, m ³ /h	1000
Motors	1
Speeds	3
Operation mode	Exhaust / Recirculation
Output hole size (mm)	120/ 150

AT 6407 ***

Net weight, kg	29,0
Gross weight, kg	31,0

AT 9407 ***

Net weight, kg	36,0
Gross weight, kg	39,0

Dimensions (H × B × T, cm)

AT 6407 ***

Unit dimensions	112,0 × 60,0 × 43,0
Dimensions in packaging	66,5 × 73,5 × 50,0

AT 9407 ***

Unit dimensions	112,0 × 90,0 × 43,0
Dimensions in packaging	73,5 × 96,5 × 50,0
Dimensions in packaging	73,5 × 96,5 × 50,0



AT 6405 Eco
AT 9405 Eco

Logic control INOX Anti touch Full touch LED

◀ 60 cm / 90 cm ▶

Stainless steel with Anti-Touch effect /smoked glass

Design

- Product line *Avantgarde^{PLUS}*

Features

- 1 Metal grease filters
- 2 charcoal filters
- Light - **LED**, 2 × 0,5 W

Equipment

- Pipe adapter 150-120 mm
- Aluminium pipe

Control

- Electronic controlled programmer **Logic control**
- Electronic full sensor control with programmer
- Full Touch**
- LCD** Display

Comfort

- Timer
- Lighting, independent of cooker hood
- Perimeter suction
- Low noise
- Dishwasher-suitable grease filters

Technical specifications

Energy efficiency class	A
Suction power, m ³ /h	910
Motors	1
Speeds	3
Operation mode	Exhaust/ Recirculation
Output hole size (mm)	120/ 150

AT 6405 Eco

Net weight, kg	17,5
Gross weight, kg	22,0

AT 9405 Eco

Net weight, kg	19,0
Gross weight, kg	25,2

Dimensions (H × B × T, cm)

AT 6405 Eco

Unit dimensions	60,0 × 60,0 × 40,5
Dimensions in packaging	62,0 × 96,0 × 53,0

AT 9405 Eco

Unit dimensions	60,0 × 90,0 × 40,5
Dimensions in packaging	62,0 × 96,0 × 53,0

WALL-MOUNTED COOKER HOODS

Avantgarde^{PLUS}



A 7425 Eco

Logic control INOX Anti touch Soft touch LED

◀ 70 cm ▶

White matt glass / Stainless steel with Anti-Touch effect
Colors-changing lighting of glass background

Design

- Product line *Avantgarde^{PLUS}*

Features

- 1 Metal grease filters
- 2 charcoal filters
- Light - **LED**, 2 × 3 W + 20 W

Equipment

- Pipe adapter 150-120 mm
- Aluminium pipe

Control

- Electronic controlled programmer **Logic control**
- Electronic full sensor control with programmer **Full Touch**
- LED** display

Comfort

- Timer
- Lighting, independent of cooker hood
- Low noise
- Dishwasher-suitable grease filters

Technical specifications

Energy efficiency class	A
Suction power, m ³ /h	910
Motors	1
Speeds	3
Operation mode	Exhaust/ Recirculation
Output hole size (mm)	120/ 150
Net weight, kg	21,3
Gross weight, kg	24,8

Dimensions (H × B × T, cm)

Unit dimensions	75,5 × 68,0 × 47,0
Dimensions in packaging	46,0 × 95,5 × 52,5



AT 6400 Eco
AT 9400 Eco

Logic control INOX Anti touch Full touch LED

◀ 60 cm / 90 cm ▶

Stainless steel with Anti-Touch effect / bluish black mirror glass

Design

- Product line *Avantgarde^{PLUS}*

Features

- 2 grease filters for 60 cm model, 3 for 90 cm model
- 2 charcoal filters
- Light - **LED**, 2 × 0,5 W

Equipment

- Pipe adapter 150-120 mm
- Aluminium pipe

Control

- Electronic controlled programmer **Logic control**
- Electronic full sensor control with programmer **Full Touch**
- LED** Display

Comfort

- Timer
- Lighting, independent of cooker hood
- Low noise
- Dishwasher-suitable grease filters

Technical specifications

Energy efficiency class	A
Suction power, m ³ /h	910
Motors	1
Speeds	3
Operation mode	Exhaust/ Recirculation
Output hole size (mm)	120/ 150
AT 6400 Eco	
Net weight, kg	14,5
Gross weight, kg	16,5
AT 9400 Eco	
Net weight, kg	18,0
Gross weight, kg	19,7

Dimensions (H × B × T, cm)

AT 6400 Eco	
Unit dimensions	45,0 × 60,0 × 50,0
Dimensions in packaging	57,0 × 66,0 × 37,5
AT 9400 Eco	
Unit dimensions	45,0 × 90,0 × 50,0
Dimensions in packaging	57,0 × 96,0 × 37,0

Avantgarde^{PLUS}

WALL-MOUNTED COOKER HOODS

Avantgarde^{PLUS}



A 4429 N

Logic control INOX Anti touch Soft touch LED

◀ 35 cm ▶

Solid stainless steel with Anti-Touch effect / blue illumination

Design

- Product line *Avantgarde^{PLUS}*

Features

- 1 Metal grease filters
- 2 charcoal filters
- Light - **LED**, 3 × 1,0 W

Equipment

- Pipe adapter 150-120 mm
- Aluminium pipe

Control

- Electronic controlled programmer
- **Logic control**
- Electronic **Soft touch** / buttons with lighting

Comfort

- Lighting, independent of cooker hood
- Low noise
- Dishwasher-suitable grease filters

Technical specifications

• Energy efficiency class	A
• Suction power, m ³ /h	1000
• Motors	1
• Speeds	3
• Operation mode	Exhaust/ Recirculation
• Output hole size (mm)	120/ 150
• Net weight, kg	15,0
• Gross weight, kg	19,5

Dimensions (H × B × T, cm)

• Unit dimensions	93,0 × 35,0 × 35,0
• Dimensions in packaging	51,5 × 99,0 × 42,0

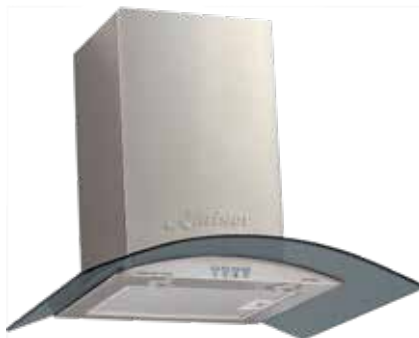

A 6419 N
A 9419 N

Logic control INOX Anti touch Soft touch

◀ 60 cm / 90 cm ▶

Stainless steel with Anti-Touch effect / smoked glass

Design

- Product line *Avantgarde^{PLUS}*

Features

- 1 Metal grease filters
- 2 charcoal filters
- Light - Halogen, 2 × 20 W

Equipment

- Pipe adapter 150-120 mm
- Aluminium pipe

Control

- Electronic controlled programmer
- **Logic control**
- Electronic **Soft touch** / buttons with lighting

Comfort

- Lighting independent of cooker hood
- Low noise
- Dishwasher-suitable grease filters

Technical specifications

• Energy efficiency class	D
• Suction power, m ³ /h	780
• Motors	1
• Speeds	3
• Operation mode	Exhaust/ Recirculation
• Output hole size (mm)	120/ 150

A 6419 ***

• Net weight, kg	16,5
• Gross weight, kg	19,0

A 9419 ***

• Net weight, kg	19,0
• Gross weight, kg	23,4

Dimensions (H × B × T, cm)

A 6419 ***

• Unit dimensions	50,0 × 60,0 × 50,0
• Dimensions in packaging	59,0 × 66,0 × 48,0

A 9419 ***

• Unit dimensions	50,0 × 90,0 × 50,0
• Dimensions in packaging	57,0 × 95,0 × 46,0

Avantgarde^{PLUS}

WALL-MOUNTED COOKER HOODS

CHEF



AT 6408 F Eco
AT 8408 F Eco

Logic control **Full touch** **INOX Anti touch** **LED**

◀ 60 cm / 80 cm ▶

Black glass with bevels / Stainless steel with Anti-Touch effect

Design

- Product line **CHEF**

Features

- 1 Metal grease filters
- 2 charcoal filters
- Light - **LED**, 2 × 1 W



AT 6409 FW Eco
AT 8409 FW Eco

Logic control **Full touch** **INOX Anti touch** **LED**

◀ 60 cm / 80 cm ▶

White glass with bevels

Equipment

- Pipe adapter 150-120 mm
- Aluminium pipe

Control

- Electronic controlled programmer **Logic control**
- Electronic full sensor control with programmer **Full Touch**
- LED** Display

Comfort

- Timer
- Lighting independent of cooker hood
- Perimeter suction
- Low noise
- Dishwasher-suitable grease filters

Technical specifications

- Energy efficiency class **A**
- Suction power, m³/h 910
- Motors 1
- Speeds 3
- Operation mode Exhaust / Recirculation
- Output hole size (mm) 120/ 150

AT 6408 F Eco / AT 6409 FW Eco

- Net weight, kg 22,5
- Gross weight, kg 26,5
- AT 8408 F Eco / AT 8409 FW Eco**
- Net weight, kg 24,0
- Gross weight, kg 28,5

Dimensions (H × B × T, cm)

AT 6408 F Eco / AT 6409 FW Eco

- Unit dimensions 103,0 × 60,0 × 45,0
- Dimensions in packaging 52,5 × 71,0 × 65,5

AT 8408 F Eco / AT 8409 FW Eco

- Unit dimensions 103,0 × 80,0 × 45,0
- Dimensions in packaging 52,5 × 91,0 × 65,5



AT 6438 F Eco
AT 8438 F Eco

INTELLIGENT SYSTEM **INOX Anti touch** **Full touch** **LED**

◀ 60 cm / 80 cm ▶

Black glass with bevels / Stainless steel with Anti-Touch effect

Design

- Product line **CHEF**

Features

- 1 Metal grease filters
- 2 charcoal filters
- Light - **LED**, 2 × 1 W



AT 6438 FW Eco
AT 8438 FW Eco

INTELLIGENT SYSTEM **INOX Anti touch** **Full touch** **LED**

◀ 60 cm / 80 cm ▶

White glass with bevels / Stainless steel with Anti-Touch effect

Equipment

- Pipe adapter 150-120 mm
- Aluminium pipe

Control

- Electronic full sensor control with programmer **Intelligent System**
- LED** indication

Comfort

- Timer
- Lighting independent of cooker hood
- Perimeter suction
- Low noise
- Dishwasher-suitable grease filters

Technical specifications

- Energy efficiency class **A**
- Suction power, m³/h 910
- Motors 1
- Speeds 3
- Operation mode Exhaust/ Recirculation
- Output hole size (mm) 120/ 150

AT 6438 F Eco

- Net weight, kg 18,0
- Gross weight, kg 20,0

AT 8438 F Eco

- Net weight, kg 19,0
- Gross weight, kg 22,0

Dimensions (H × B × T, cm)

AT 6438 F Eco

- Unit dimensions 78,0 × 60,0 × 37,5
- Dimensions in packaging 49,0 × 65,5 × 48,0

AT 8438 F Eco

- Unit dimensions 78,0 × 80,0 × 37,5
- Dimensions in packaging 49,0 × 85,0 × 48,0

CHEF

WALL-MOUNTED COOKER HOODS



AT 6445 EifAD Eco
AT 9445 EifAD Eco

INTELLIGENT SYSTEM **Full touch** **LED** **Antique Gold**

◀ 60 cm / 90 cm ▶

Ivory glass, decor Antique Gold

Design

- Product line **ART DÉCO**
- Ivory glass with metal fittings **Antique Gold**

Features

- 1 Metal grease filters
- 2 charcoal filters
- Light - **LED**, 2 × 2,5 W

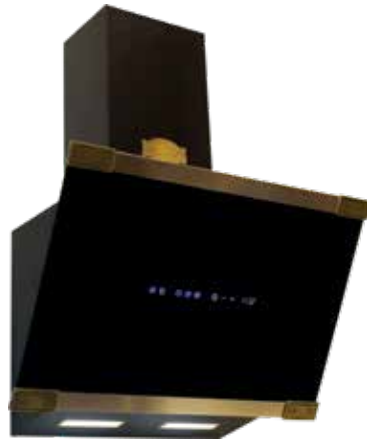

AT 6445 AD Eco
AT 9445 AD Eco

INTELLIGENT SYSTEM **Full touch** **LED** **Antique Gold**

◀ 60 cm / 90 cm ▶

Black glass, decor Antique Gold

Equipment

- Pipe adapter 150-120 mm
- Aluminium pipe

Control

- Electronic full sensor control with programmer **Intelligent System**
- **LED** indication

Comfort

- Timer
- Lighting independent of cooker hood
- Perimeter suction
- Low noise
- Dishwasher-suitable grease filters

Technical specifications

- Energy efficiency class **A**
- Suction power, m³/h 1250
- Motors 1
- Speeds 3
- Operation mode Exhaust/ Recirculation
- Output hole size (mm) 120/ 150

AT 6445 EifAD/AD Eco

- Net weight, kg 10,6
- Gross weight, kg 14,2

AT 9445 EifAD Eco

- Net weight, kg 14,3
- Gross weight, kg 19,0

Dimensions (H × B × T, cm)

- Unit dimensions 75,5 × 90,0 × 37,5
 - Dimensions in packaging 43,5 × 71,0 × 46,0
- AT 9445 EifAD/AD Eco**
- Unit dimensions 75,5 × 90,0 × 37,5
 - Dimensions in packaging 43,5 × 71,0 × 46,0

ART DÉCO



A 6315 Em
A 9315 Em

PUSH **LED** **Bronze**

◀ 60 cm / 90 cm ▶

Anthracite coloured enamel

Design

- Product line **Empire**
- Antique Decor
- Decor - solid metal **Bronze**

Features

- 2 grease filters for 60 cm model, 3 for 90 cm models
- 2 charcoal filters
- Light - **LED**, 2 × 2,0 W

Equipment

- Pipe adapter 150-120 mm
- Aluminium pipe



A 6315 EifEm
A 9315 EifEm

PUSH **LED** **Bronze**

◀ 60 cm / 90 cm ▶

Ivory coloured enamel

Control

- Push buttons **Bronze**

Comfort

- Lighting independent of cooker hood
- Low noise
- Dishwasher-suitable grease filters

Technical specifications

- Energy efficiency class **A**
- Suction power, m³/h 910
- Motors 1
- Speeds 3
- Operation mode Exhaust /Recirculation
- Output hole size (mm) 120/ 150



A 6315 RotEm
A 9315 RotEm

PUSH **LED** **Bronze**

◀ 60 cm / 90 cm ▶

Bordeaux coloured enamel

A 6315 ***

- Net weight, kg 12,5
- Gross weight, kg 16,0

A 9315 ***

- Net weight, kg 14,5
- Gross weight, kg 18,0

Dimensions (H × B × T, cm)

- Unit dimensions 86,5 × 60,0 × 48,0
 - Dimensions in packaging 56,0 × 68,0 × 36,0
- A 9315 *****
- Unit dimensions 86,5 × 90,0 × 48,0
 - Dimensions in packaging 56,0 × 98,0 × 36,0

Empire

WALL-MOUNTED COOKER HOODS

*Belle
Époque*



A 6423 GrBE Eco
A 9423 GrBE Eco

PUSH  **Antique Gold**

◀ 60 cm / 90 cm ▶

Grey coloured enamel, decor Antique Gold



A 6423 RotBE Eco
A 9423 RotBE Eco

PUSH  **Antique Gold**

◀ 60 cm / 90 cm ▶

Bordeaux coloured enamel, decor Antique Gold



A 6423 EifBE Eco
A 9423 EifBE Eco

PUSH  **Antique Gold**

◀ 60 cm / 90 cm ▶

Ivory coloured enamel, decor Antique Gold

Design

- Product line *Belle Époque*
- Chimney hood
- Decor – solid metal Antique Gold
- Art Déco-leather covered handle's rod
- Metal parts Antique Gold with convex coat of arms

Features

- 2 Metal grease filters
- 2 charcoal filters
- Light – **LED**, 2 × 2,0 W

Equipment

- Pipe adapter 150-120 mm
- Aluminium pipe



A 6423 BE Eco
A 9423 BE Eco

PUSH  **Antique Gold**

◀ 60 cm / 90 cm ▶

Anthracite coloured enamel, decor Antique Gold

Control

- Push buttons **Push Antique Gold**

Comfort

- Lighting independent of cooker hood
- Low noise
- Dishwasher-suitable grease filters

Technical specifications

- Energy efficiency class **A**
- Suction power, m³/h 910
- Motors 1
- Speeds 3
- Operation mode Exhaust/ Recirculation
- Output hole size (mm) 120/ 150
- **AT 6445 EifAD Eco**
- Net weight, kg 10,6
- Gross weight, kg 14,2



A 6423 BluBE Eco
A 9423 BluBE Eco

PUSH  **Antique Gold**

◀ 60 cm / 90 cm ▶

Azure coloured enamel, decor Antique Gold

AT 9445 EifAD Eco

- Net weight, kg 14,3
- Gross weight, kg 19,0

Dimensions (H × B × T, cm)

- **A 6423 *BE Eco**
- Unit dimensions 69,5 × 60,0 × 50,0
- Dimensions in packaging 57,0 × 66,0 × 37,0

A 9423 *BE Eco

- Unit dimensions 69,5 × 90,0 × 50,0
- Dimensions in packaging 57,0 × 66,0 × 40,0

*Belle
Époque*

ISLAND COOKER HOODS



AI 9415 Eco

INTELLIGENT SYSTEM

Full touch

INOX Anti touch

LED

◀ 90 cm ▶

Remote Control

Black glass

Design

- Product line *Avantgarde*
- Black glass

Features

- 2 Metal grease filters
- 2 charcoal filters
- Light - LED, 2 x 1,5 W

Equipment

- Pipe adapter 150-120 mm
- Aluminium pipe

Control

- Electronic full sensor control with programmer **Intelligent System**
- LED Display
- Remote control

Comfort

- Timer
- Lighting, independent of cooker hood
- Perimeter suction
- Low noise
- Dishwasher-suitable grease filters

Technical specifications

• Energy efficiency class	A
• Suction power, m ³ /h	1250
• Motors	1
• Speeds	3
• Operation mode	Exhaust/ Recirculation
• Output hole size (mm)	120/ 150
• Net weight, kg	25,5
• Gross weight, kg	33,0

Dimensions (H × B × T, cm)

- Unit dimensions 98,5 × 90,0 × 81,5
- Dimensions in packaging 100,0 × 87,0 × 50,5



AI 7418 Eco

INTELLIGENT SYSTEM

Soft touch

INOX Anti touch

LED

◀ 70 cm ▶

Remote Control

Black glass/ Stainless steel

Design

- Product line *Avantgarde*
- Glass / stainless steel with **Anti touch**-effect

Features

- 1 Metal grease filters
- 2 charcoal filters
- Light - LED, 4 × 3,0 W

Equipment

- Pipe adapter 150-120 mm
- Aluminium pipe

Control

- Electronic **Intelligent System** / Soft touch buttons with lighting
- LED Display
- Remote control



AI 7418 W Eco

INTELLIGENT SYSTEM

Soft touch

INOX Anti touch

LED

◀ 70 cm ▶

Remote Control

White matt glass/ Stainless steel

Comfort

- Lighting, independent of cooker hood
- Perimeter suction
- Low noise
- Dishwasher-suitable grease filters

Technical specifications

• Energy efficiency class	A
• Suction power, m ³ /h	1250
• Motors	1
• Speeds	3
• Operation mode	Exhaust/ Recirculation
• Output hole size (mm)	120/ 150
• Net weight, kg	25,5
• Gross weight, kg	33,0

Dimensions (H × B × T, cm)

- Unit dimensions 98,5 × 70,0 × 60,0
- Dimensions in packaging 76,5 × 66,0 × 46,0/ 30,5 × 28,5 × 62,5

Avantgarde PRO

ISLAND COOKER HOODS

Avantgarde **PRO**



AI 5405 W

INTELLIGENT SYSTEM

Full touch



Remote Control

◀ 40 cm ▶

White glass

Design

- Product line *Avantgarde*



AI 5405 S

INTELLIGENT SYSTEM

Full touch



Remote Control

◀ 40 cm ▶

Black glass

Features

- 1 Metal grease filters
- 2 charcoal filters
- Light - **LED**, 2 x 2,5 W

Design

- Product line *Avantgarde*

Features

- 1 Metal grease filters
- 2 charcoal filters
- Light - **LED**, 2 x 2,5 W

Equipment

- Pipe adapter 150-120 mm
- Aluminium pipe

Control

- Electronic full sensor control with programmer **Intelligent System**
- LED** Display
- Remote control

Equipment

- Pipe adapter 150-120 mm
- Aluminium pipe

Control

- Electronic full sensor control with programmer **Intelligent System**
- LED** Display
- Remote control

Comfort

- Timer
- Lighting, independent of cooker hood
- Perimeter suction
- Low noise
- Dishwasher-suitable grease filters

Technical specifications

	A
Energy efficiency class	910
Suction power, m ³ /h	1
Motors	3
Speeds	3
Operation mode	Exhaust/ Recirculation
Output hole size (mm)	120/ 150
Net weight, kg	21,0
Gross weight, kg	23,5

Dimensions (H x B x T, cm)

Unit dimensions	38,0 x 50,0 x 40,0
Dimensions in packaging	42,0 x 57,0 x 45,0

Comfort

- Timer
- Lighting, independent of cooker hood
- Low noise
- Dishwasher-suitable grease filters

Technical specifications

	A
Energy efficiency class	910
Suction power, m ³ /h	1
Motors	3
Speeds	3
Operation mode	Exhaust/ Recirculation
Output hole size (mm)	120/ 150
Net weight, kg	17,0
Gross weight, kg	19,0

Dimensions (H x B x T, cm)

Unit dimensions	38,0 x 40,0 x 40,0
Dimensions in packaging	42,0 x 57,0 x 45,0



AI 5407

INTELLIGENT SYSTEM

Full touch



Remote Control

INOX
Anti touch

◀ 40 cm ▶

Stainless steel with Anti touch effect

Design

- Product line *Avantgarde*

Features

- 1 Metal grease filters
- 2 charcoal filters
- Light - **LED**, 1 x 16 W

Equipment

- Pipe adapter 150-120 mm
- Aluminium pipe

Control

- Electronic full sensor control with programmer **Intelligent System**
- LED** Display
- Remote control

Comfort

- Light panel - **LED**, 2 x 3,0 W
- Timer
- Perimeter suction
- Lighting, independent of cooker hood

- Low noise

- Dishwasher-suitable grease filters

Technical specifications

	A
Energy efficiency class	1250
Suction power, m ³ /h	1
Motors	3
Speeds	3
Operation mode	Exhaust/ Recirculation
Output hole size (mm)	120/ 150
Net weight, kg	36,0
Gross weight, kg	40,0

Dimensions (H x B x T, cm)

Unit dimensions	60,0 x 90,0 x 60,0
Dimensions in packaging	96,0 x 45,5 x 66,5



AI 9434 W Eco

INTELLIGENT SYSTEM

Full touch



Remote Control

INOX
Anti touch

◀ 90 cm ▶

White matt glass/ Stainless steel with Anti touch effect

Avantgarde **PRO**

ISLAND COOKER HOODS

Avantgarde^{PLUS}



AI 4428 Eco

Logic control **Soft touch** INOX Anti touch LED

◀ 35 cm ▶

Solid stainless steel with Anti-Touch effect/ blue illumination

Design

- Product line *Avantgarde*

Features

- 1 Metal grease filters
- 2 charcoal filters
- Light - **LED**, 3 × 1,0 W

Equipment

- Pipe adapter 150-120 mm
- Aluminium pipe

Control

- Electronic **Intelligent System / Soft touch** buttons with **LED** lighting

Comfort

- Lighting, independent of cooker hood
- Low noise
- Dishwasher-suitable grease filters

Technical specifications

- Energy efficiency class **A**
- Suction power, m³/h 1000
- Motors 1
- Speeds 3
- Operation mode Exhaust/ Recirculation
- Output hole size (mm) 120/ 150
- Net weight, kg 15,0
- Gross weight, kg 19,5

Dimensions (H × B × T, cm)

- Unit dimensions 93,0 × 35,0 × 35,0
- Dimensions in packaging 51,5 × 99,0 × 42,0



AI 9401 Eco

Logic control **Soft touch** INOX Anti touch LED

◀ 90 cm ▶

Stainless steel with Anti-Touch effect/ smoked glass

Design

- Product line *Avantgarde*
- Stainless steel with **Anti-Touch** effect / smoke colored glass

Features

- 1 Metal grease filters
- 2 charcoal filters
- Light - **LED**, 4 × 2 W

Equipment

- Pipe adapter 150-120 mm
- Aluminium pipe

Control

- Electronic controlled programmer **Logic control**
- Soft touch** buttons with lighting

Comfort

- Lighting independent of cooker hood
- Low noise
- Dishwasher-suitable grease filters

Technical specifications

- Energy efficiency class **A**
- Suction power, m³/h 910
- Motors 1
- Speeds 3
- Operation mode Exhaust/ Recirculation
- Output hole size (mm) 120/ 150
- Net weight, kg 32,5
- Gross weight, kg 38,4

Dimensions (H × B × T, cm)

- Unit dimensions 65,0 × 90,0 × 90,0
- Dimensions in packaging 68,0 × 66,0 × 38,5



AI 7403 Eco

Logic control **Soft touch** INOX Anti touch LED

◀ 70 cm ▶

White matt glass/ Stainless steel with Anti-Touch effect
Colors-changing lighting of glass background

Design

- Product line *Avantgarde*

Features

- 1 Metal grease filters
- 2 charcoal filters
- Light - **LED**, 2 × 3 W + 20 W

Equipment

- Pipe adapter 150-120 mm
- Aluminium pipe

Control

- Electronic controlled programmer **Logic control**
- Soft touch** buttons with lighting

Comfort

- Lighting independent of cooker hood

- Perimeter suction
- Low noise
- Dishwasher-suitable grease filters

Technical specifications

- Energy efficiency class **A**
- Suction power, m³/h 910
- Motors 1
- Speeds 3
- Operation mode Exhaust/ Recirculation
- Output hole size (mm) 120/ 150
- Net weight, kg 30,7
- Gross weight, kg 35,0

Dimensions (H × B × T, cm)

- Unit dimensions 95,6 × 68,0 × 48,0
- Dimensions in packaging 75,5 × 55,5 × 53,0 / 36,5 × 36,5 × 64,0



ISLAND COOKER HOODS

Avantgarde^{PLUS}



AI 4406 W

Soft touch **Logic control** **INOX Anti touch** **LED**

◀ 50 cm ▶

White glass

Design

- Product line *Avantgarde^{PLUS}*

Features

- 1 Metal grease filters
- 2 charcoal filters
- Light - **LED**, 2 × 2,5 W

Equipment

- Pipe adapter 150-120 mm
- Aluminium pipe

Control

- Electronic **Intelligent System** / **Soft touch** buttons with **LED** lighting
- **LED** Display

Comfort

- Lighting, independent of cooker hood
- Low noise
- Dishwasher-suitable grease filters

Technical specifications

• Energy efficiency class	A
• Suction power, m ³ /h	910
• Motors	1
• Speeds	3
• Operation mode	Exhaust/ Recirculation
• Output hole size (mm)	120/ 150
• Net weight, kg	21,0
• Gross weight, kg	23,5

Dimensions (H × B × T, cm)

• Unit dimensions	38,0 × 35,2 × 35,2
• Dimensions in packaging	58,0 × 53,5 × 58,5



AI 9404 Eco

INTELLIGENT SYSTEM **Full touch** **INOX Anti touch** **LED**

◀ 90 cm ▶

Stainless steel with Anti touch effect

Design

- Product line *Avantgarde^{PLUS}*

Features

- 3 Metal grease filters
- 2 charcoal filters
- Light - **LED**, 2 × 0,5 W

Equipment

- Pipe adapter 150-120 mm
- Aluminium pipe

Control

- Electronic controlled programmer
- **Logic control**
- **Soft touch** buttons with lighting

Comfort

- Lighting, independent of cooker hood
- Low noise
- Dishwasher-suitable grease filters

Technical specifications

• Energy efficiency class	A
• Suction power, m ³ /h	1250
• Motors	1
• Speeds	3
• Operation mode	Exhaust/ Recirculation
• Output hole size (mm)	120/ 150
• Net weight, kg	28,5
• Gross weight, kg	32,4

Dimensions (H × B × T, cm)

• Unit dimensions	101,0 × 90,0 × 60,0
• Dimensions in packaging	43,5 × 95,5 × 66,0

Avantgarde^{PLUS}

BUILT-IN COOKER HOODS



EA 1047 W Eco

INTELLIGENT SYSTEM Full touch LED Remote Control

◀ 110 cm ▶

White glass/ Stainless steel with Anti touch effect

Design

- Product line Avantgarde
- Ceiling hood with perimeter suction

Features

- 2 Metal grease filters
- Light - LED, 1 × 8,0 W

Equipment

- Pipe adapter 150-120 mm
- Aluminium pipe

Control

- Electronic full sensor control with programmer Intelligent System
- Remote control

Comfort

- Timer
- Lighting, independent of cooker hood
- Perimeter suction
- Low noise
- Dishwasher-suitable grease filters

Technical specifications

Energy efficiency class	A
Suction power, m ³ /h	1250
Motors	1
Speeds	3
Operation mode	Exhaust/ Recirculation
Output hole size (mm)	120/ 150
Net weight, kg	32,5
Gross weight, kg	37,0

Dimensions (H × B × T, cm)

Unit dimensions	27,0 × 110,0 × 70,0
Dimensions in packaging	78,0 × 120,0 × 38,0



EA 1145 S Eco

INTELLIGENT SYSTEM Soft touch LED INOX Anti touch Remote Control

◀ 120 cm ▶

Black steel with Anti touch effect

Design

- Product line Avantgarde
- Ceiling hood with perimeter suction

Features

- 4 Metal grease filters
- Light - LED, 2 × 5,0 W

Equipment

- Pipe adapter 150-120 mm
- Aluminium pipe

Control

- Electronic control Intelligent System / Soft touch buttons with LED lighting
- Remote control



EA 1145 Eco

INTELLIGENT SYSTEM Soft touch LED INOX Anti touch Remote Control

◀ 120 cm ▶

Stainless steel with Anti touch effect

Comfort

- Lighting, independent of cooker hood
- Perimeter suction
- Low noise
- Dishwasher-suitable grease filters

Technical specifications

Energy efficiency class	A
Suction power, m ³ /h	1250
Motors	1
Speeds	3
Operation mode	Exhaust/ Recirculation
Output hole size (mm)	120/ 150
Net weight, kg	30,0
Gross weight, kg	30,3

Dimensions (H × B × T, cm)

Unit dimensions	78,5 × 119,5 × 39,5
Dimensions in packaging	42,0 × 57,0 × 45

BUILT-IN COOKER HOODS



EA 546 W Eco
EA 946 W Eco

INTELLIGENT SYSTEM **Full touch** **LED** **Remote Control**

◀ 50 cm / 90 cm ▶

White glass / Stainless steel with Anti touch effect

Design

- Product line *Avantgarde*
- Built-under hood with perimeter suction
- EA 946 can also be used as a ceiling hood

Features

- 1 Metal grease filters
- 2 charcoal filters
- Light – 1 × 16,0 W

Equipment

- Pipe adapter 150-120 mm
- Aluminium pipe

Control

- Electronic full sensor control with programmer **Intelligent System**
- **LED** Display
- Remote control

Comfort

- Lighting, independent of cooker hood
- Perimeter suction
- Low noise
- Dishwasher-suitable grease filters

Technical specifications

• Energy efficiency class	A
• Suction power, m ³ /h	910
• Motors	1
• Speeds	3
• Operation mode	Exhaust/ Recirculation
• Output hole size (mm)	120/ 150
EA 546 W Eco	
• Net weight, kg	9,5
• Gross weight, kg	11,5
EA 946 W Eco	
• Net weight, kg	12,0
• Gross weight, kg	14,0

Dimensions (H × B × T, cm)

EA 546 W Eco	
• Unit dimensions	30,7 × 52,0 × 29,6
• Dimensions in packaging	56,5 × 41,0 × 34,0
EA 946 W Eco	
• Unit dimensions	30,7 × 90,0 × 29,6
• Dimensions in packaging	94,5 × 37,5 × 34,0



EA 745 Eco
EA 945 Eco

INTELLIGENT SYSTEM **Soft touch** **LED**

◀ 70 cm / 90 cm ▶

Stainless steel with Anti-Touch effect

Design

- Product line *Avantgarde*
- Built-under hood

Features

- 2 Metal grease filters
- 2 charcoal filters
- Light – 1 × 16,0 W
- Stainless steel baffle filter

Equipment

- Pipe adapter 150-120 mm
- Aluminium pipe

Control

- Electronic control **Intelligent System** / **Soft touch** buttons with **LED** lighting

Comfort

- Lighting, independent of cooker hood
- Low noise
- Dishwasher-suitable grease filters

Technical specifications

• Energy efficiency class	A+
• Suction power, m ³ /h	1000
• Motors	1
• Speeds	3
• Operation mode	Exhaust/ Recirculation
• Output hole size (mm)	120/ 150
EA 546 W Eco	
• Net weight, kg	9,5
• Gross weight, kg	11,5
EA 946 W Eco	
• Net weight, kg	12,0
• Gross weight, kg	14,0

Dimensions (H × B × T, cm)

EA 546 W Eco	
• Unit dimensions	30,7 × 52,0 × 29,6
• Dimensions in packaging	56,5 × 41,0 × 34,0
EA 946 W Eco	
• Unit dimensions	30,7 × 90,0 × 29,6
• Dimensions in packaging	94,5 × 37,5 × 34,0

Avantgarde **PRO**



EA 543 N
EA 743 N

Logic control **Soft touch** **INOX Anti touch** **LED**

◀ 50 cm / 70 cm ▶

Stainless steel with Anti-Touch effect

Design

- Product line *Avantgarde*
- Built-under hood

Features

- 1 Metal grease filters
- 2 charcoal filters
- Light - **LED**, 2 × 2,5 W

Equipment

- Pipe adapter 150-120 mm
- Aluminium pipe

Control

- Electronic control **Intelligent System** / **Soft touch** buttons with **LED** lighting

Comfort

- Lighting, independent of cooker hood
- Low noise
- Dishwasher-suitable grease filters

Technical specifications

• Energy efficiency class	A
• Suction power, m ³ /h	1000
• Motors	1
• Speeds	3
• Operation mode	Exhaust/ Recirculation
• Output hole size (mm)	120/ 150
EA 543 N	
• Net weight, kg	7,4
• Gross weight, kg	9,2
EA 743 N	
• Net weight, kg	8,2
• Gross weight, kg	10,1

Dimensions (H × B × T, cm)

EA 543 N	
• Unit dimensions	31,4 × 52,0 × 29,6
• Dimensions in packaging	32,0 × 64,0 × 32,5
EA 743 N	
• Unit dimensions	31,4 × 70,0 × 29,6
• Dimensions in packaging	31,5 × 73,0 × 33,0

Avantgarde **PLUS**

BUILT-IN COOKER HOODS



EA 644 Eco

INTELLIGENT SYSTEM **Teleskop** **Full touch** **LED**

◀ 60 cm ▶

Black glass / Stainless steel with Anti touch effect

Design

- Product line **Avantgardē**
- Built-in hood

Features

- 2 Metal grease filters
- 2 charcoal filters
- Light - **LED**, 2 × 2,5 W



EA 644 W Eco

INTELLIGENT SYSTEM **Teleskop** **Full touch** **LED**

◀ 60 cm ▶

White glass / Stainless steel with Anti touch effect

Equipment

- Pipe adapter 150-120 mm
- Aluminium pipe

Control

- Electronic full sensor control with programmer **Intelligent System**
- **LED** indication

Features

- 2 Metal grease filters
- 2 charcoal filters
- Light - **LED**, 2 × 2,5 W

Equipment

- Pipe adapter 150-120 mm
- Aluminium pipe

Control

- Electronic full sensor control with programmer **Intelligent System**
- **LED** indication

Comfort

- Timer
- Lighting, independent of cooker hood
- Low noise
- Dishwasher-suitable grease filters

Comfort

- Timer
- Lighting, independent of cooker hood
- Low noise
- Dishwasher-suitable grease filters

Technical specifications

• Energy efficiency class	A
• Suction power, m ³ /h	910
• Motors	1
• Speeds	3
• Operation mode	Exhaust/ Recirculation
• Output hole size (mm)	120/ 150
• Net weight, kg	11,0
• Gross weight, kg	12,6

Dimensions (H × B × T, cm)

• Unit dimensions	27,0 x 60,0 x 36,0
• Dimensions in packaging	35,5 x 66,0 x 31,5

Avantgardē PLUS



EA 644 ElfEm Eco

INTELLIGENT SYSTEM **Teleskop** **Full touch** **LED**

◀ 60 cm ▶

Ivory glass / ivory colored

Design

- Product line **Empire**
- Built-in hood

Technical specifications

• Energy efficiency class	A
• Suction power, m ³ /h	910
• Motors	1
• Speeds	3
• Operation mode	Exhaust/ Recirculation
• Output hole size (mm)	120/ 150
• Net weight, kg	11,0
• Gross weight, kg	12,6

Dimensions (H × B × T, cm)

• Unit dimensions	27,0 x 60,0 x 36,0
• Dimensions in packaging	35,5 x 66,0 x 31,5

Empire





Microwaves

MICROWAVES

Microwaves in *Avantgarde*, *Empire* and *ART DÉCO* designs will give a new shine to your kitchen. Thanks to the elegant and retro designs, finishing in stainless steel with Anti touch effect your microwaves can be easily combined with other household appliances Kaiser and give your kitchen designing more free space.

The microwave oven is equipped with tangential cooling air system, which protects the kitchen furniture from excessive heating.



Glass turntable and stainless steel grid as well as universal **Wonder-Plate** with non-stick coating offers the possibility to prepare the food in different ways and also use a quartz grill.



All microwaves *Kaiser* have stainless steel cavity. The microwaves are also equipped with the stainless steel grill and the glass turntable, which are suitable for washing in dishwasher.

Dimensions of built-in microwave *Kaiser* allow the installing of the appliance in any type of kitchen furniture.



The electronic control **Intelligent System** allows you to select the operating functions, presser programs according time, use various programs for defrosting or for heating.

If you select operating function, then you can defrost, heat, etc., and also cook your favourite dishes as in an oven.

A special feature of these microwaves is the automatic defrosting according weight and set cooking time. Few movements are enough to get a well-defrosted product in a few minutes!

The microwaves have **Full touch** sensor control, button control and rotary stainless steel knob, it offers more operation convenience.

The adjustable feet allow you to install a built-in microwave horizontally in a niche.

The design and the material of the feet ensure a stable fixation of microwave and minimize vibrations and noise.

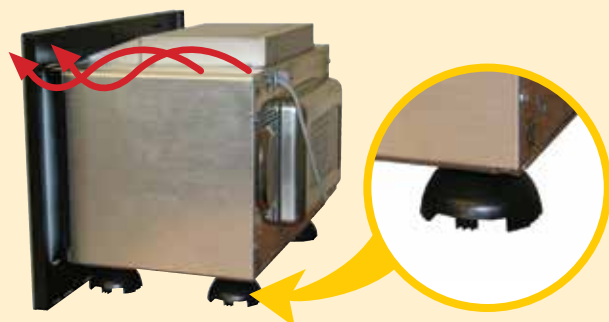

BUILT-IN MICROWAVE OVENS WITH QUARTZ GRILL AND CONVECTION

Multi 21



x
5



x
5



x
6



x
3



x
3



x
5



EM 2510

Mikrowelle Full INTELLIGENT
Quartz grill touch SYSTEM

Power Circle

Black PMMA glass

Design

- Product line *Avantgarde*

Features

- Stainless steel interior
- Circulation system
- Electronic timer



EM 2520

Mikrowelle Full INTELLIGENT INOX
Quartz grill touch SYSTEM Anti touch

Stainless steel with Anti touch effect / black glass

Equipment

- 1 Chromed multifunction roast shelf
- 1 Turnable plate Ø 27 cm

Control

- Electronic sensor-controlled programmer Intelligent System
- Multifunctional LED display
- Child safety lock

Comfort

- F 21 AUTOMATIK – Multifunctional microwave oven with quartz grill and hot air
- 5 Microwave power levels
- 3 Microwave + Hot air power levels
- 3 Microwave + Grill power level
- 10 Automatic programmes
- 4 user programmes
- Automatic defrost, heating, and cooking of various types of products according time and weight
- Door opening push button

Technical specifications

Usable volume, l.	25
Microwave power, kW	0,9
Grill power, kW	1,3
Hot air power, kW	2,3
Total power, kW	1,4
Net weight, kg	17,4
Gross weight, kg	19,70

Dimensions (H x W x D, cm)

Unit dimensions	34,5 x 59,5 x 39,0
Niche dimensions	37,8 x 60,0 x 55,5
Dimensions in packaging	66,5 x 46,0 x 20,5

Avantgarde PRO

Multi 21



x
5



x
5



x
6



x
3



x
3



x
5



EM 2545 AD

Mikrowelle Full INTELLIGENT
Quartz grill touch SYSTEM

Power Circle Antique Gold

Antracite-colored PMMA glass, door handle and metal fittings Antique Gold

Design

- Product line *ART DÉCO*

Features

- Stainless steel interior
- Circulation system
- Electronic timer



EM 2545 EIFAD

Mikrowelle Full INTELLIGENT INOX
Quartz grill touch SYSTEM Anti touch

Power Circle Antique Gold

Ivory-colored PMMA glass, door handle and metal fittings Antique Gold

Equipment

- 1 Chromed multifunction roast shelf
- 1 Turnable plate Ø 27 cm

Control

- Electronic sensor-controlled programmer Intelligent System
- Multifunctional LED display
- Child safety lock

Comfort

- Microwave oven with quartz grill and hot air
- 5 Microwave power levels
- 3 Microwave + Hot air power levels
- 3 Microwave + Grill power level
- 10 Automatic programmes
- 4 user programmes
- Automatic defrost, heating, and cooking of various types of products according time and weight
- Door opening push button

Technical specifications

Usable volume, l.	25
Microwave power, kW	0,9
Grill power, kW	1,3
Hot air power, kW	2,3
Total power, kW	1,4
Net weight, kg	17,4
Gross weight, kg	19,70

Dimensions (H x W x D, cm)

Unit dimensions	34,5 x 59,5 x 39,0
Niche dimensions	37,8 x 60,0 x 55,5
Dimensions in packaging	66,5 x 46,0 x 20,5

ART DÉCO

FREE-STANDING MICROWAVE OVENS WITH QUARTZ GRILL AND CONVECTION

Multi 21



M 2500 EM

Mikrowelle Full INTELLIGENT Quartz grill touch SYSTEM Bronze

Black glass / solid metal Bronze

Design

- Product line **Empire**

Features

- Stainless steel interior
- Circulation system
- Electronic timer

Equipment

- 1 Chromed multifunction roast shelf
- 1 Turnable plate Ø 27 cm

Control

- Electronic sensor-controlled programmer **Intelligent System**
- Multifunctional **LED** display
- Child safety lock



M 2500 EIFEM

Mikrowelle Full INTELLIGENT Quartz grill touch SYSTEM Bronze

Ivory glass / solid metal Bronze

Comfort

- F 21 AUTOMATIK – Multifunction microwave oven with quartz grill and hot air
- 5 Microwave power levels
- 3 Microwave + Hot air power levels
- 3 Microwave + Grill power level
- 10 Automatic programmes
- 4 user programmes
- Automatic defrost, heating, and cooking of various types of products according time and weight
- Door opening push button

Technical specifications

- Usable volume, l. 25
- Microwave power, kW 0,9
- Grill power, kW 1,3



M 2500 RotEM

Mikrowelle Full INTELLIGENT Quartz grill touch SYSTEM Bronze

Bordeaux glass / Metall Bronze

Dimensions

- Hot air power, kW 2,3
- Total power, kW 1,4
- Net weight, kg 14,3
- Gross weight, kg 15,8

Dimensions (H x W x D, cm)

- Unit dimensions 29,4 x 49,4 x 37,0
- Dimensions in packaging 30,6 x 54,5 x 48,4

Empire



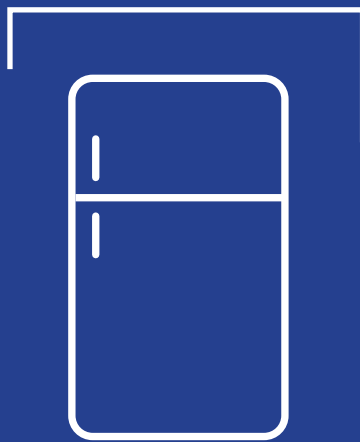

Refrigerators

REFRIGERATORS



The fridge-freezers *Kaiser* are your best partners. You can rely on a storage or maintenance of fresh and healthy foods.

The optimal combination of fridge and freezer compartments, the application of environmental and health-friendly materials in connection with the latest technological engineering are just some features which make refrigerators *Kaiser* so attractive and common to all who care about own health.

Our innovative system **BIO Safe**: an extra compartment which is equipped with an electronic temperature control. Your food can be frozen without loss of moisture. In **BIO Safe** can be gently freeze, allowing that food can be prepared immediately after removal it without thawing. In addition the food increases at the temperatures from about 0 °C its storage life.

The fridge-freezers *Kaiser Side-by-Side* offer plenty of space, in conjunction with the technical innovations and ease of operation.

FRIDGE FREEZERS SIDE-BY-SIDE

The fridge-freezers **Side-by-Side** have **LED** lighting in both chambers, the door shelves there are at the two doors. It allows to keep the various goods with high comfort.



The fridge-freezers *Kaiser* have an energy efficiency class **A+**: they consume about 15 % less of electric energy than fridge-freezers with class A. And that's thanks to the excellent thermal insulation and the high quality inverter compressors.



Inverter Compressors

Reduced power consumption, significantly lower noise level and long life time of the compressor. The Inverter compressors provide precise temperature control, the food will stay fresh longer. The temperature sensors in association with microprocessor technology optimise the engine performance for a maximum efficiency of cooling and freezing.



The unit defrosts automatically so that the maintenance and service of the refrigerator is kept to a minimum. The uniform temperature distribution is achieved in all chambers thanks to air recirculation, fine and precise temperature control in the chambers serves for fast cooling and freezing. Moreover this function provides fast recovery of the temperature level in the chamber after loading with multiple goods or after several door openings (positive impact on the quality of the food cooling and storage, energy saving).



Electronic **LED** equipment. The keeping quality of fruit and vegetables raises effectively thanks to the special developed **LED** lighting cycles which improve the daylight.



The capacious drink bar is equipped with its own small door. Just push the door to get your favourite cold beverage. Kaiser **MULTI-BAR** also has storage for four beverage cans.

FRIDGE FREEZER COMBINATIONS



Intelligent System

The electronic control. Full control of the electronic system of the appliance and optimization of its work. It provides a wide range of temperature regulation of -22°C to $+8^{\circ}\text{C}$, hereby it allows flexible and accurate setting for a maximum food storage. Separate control of the operating functions for the fridge and freezer compartments.

Door racks

The door racks **KAISER LOGIC SPACE** allow to place on them different goods like bottles, butter/ cheese boxes, eggs etc.

Bottle holder

The special space-saving, elegant, chrome plated tray is suitable for up to 5 bottles.

Height-adjustable glass shelves

The extendable glass tops **KAISER SAFETY GLASS** are made from impact resistant, not scratchable, dishwasher suitable glass. The glass shelves provide optional use of the storage space and offer enough space for high objects like decanters, bottles, pots, etc.



Among other things the **Zero-Zone** allows gentle freezing. The isolated highly effective special compartment is designed for the best storage, cooling and freezing of meat, fish, fruit, vegetables and baby food. It is equipped with an electronic temperature control, so the food without loss of moisture to be frozen. It allows to prepare a food immediately after removal without thawing.



Fruit and vegetable crisper allows to retain the right moisture content. The insulated compartment with ventilation and humidity control helps to preserve the moisture and nutrients of food.



Transparent freezer compartment made of frost-proof plastic. It allows, in comparison to traditional food storage conditions to maintain flavour and nutritional benefits immutable.

The **Super Frost** function allows a rapid freezing of stored food. The freezer compartment switches to normal operation in 24 or max. in 48 hours.



Signal – open door: if the door is open more than 90 seconds, the acoustic signals remind you that the door must be closed. The acoustic signals will stop after closing the door.



Holiday mode

In this operation, the temperature is set in the freezer at -15°C and in the refrigerator at 7°C . After the holiday mode is cancelled, the temperature goes back in the refrigerator to previously set values.



Environmental protection

The company's philosophy is not only based on the principle of high quality, but also focuses attention on eco-friendliness. The refrigerators by **Kaiser** are 100% recyclable. They are produced according to the US norms which means that no raw materials causing environmental pollution are used in the process of manufacture and the refrigerating agent R 600 A contains no components destroying the ozone layer. The insulation of the freezing compartments is made of the neutral for the environment foamed polyurethane and contains no harmful substances.



REFRIGERATORS

FRIDGE FREEZER COMBINATION

Empire



KK 70575 Em

Bronze



Anthracite colored

Design

- Product line **Empire**
- Decor – solid metal **Bronze**

Control

- Electronic full sensor control with programmer Intelligent System
- Multifunction LED-display
- Child safety lock



KK 70575 ElfEm



Ivory colored

Comfort

- **No-frost**
- **Cloud Fresh**
- **BIO SAFE**
- **Garden Box**
- Height-adjustable shelves made of high-quality safety glass
- **FREEZE BOX**
- Super Frost
- Audible beeps
- Holiday mode
- Eye-friendly **LED** illumination
- Reversible door (L/R)
- Low noise
- Storage temperature up to -22°C , deep freezing
- Temperature increase alarm

Equipment

- Fridge shelves
- Vegetable / fruit crispers
- Egg tray
- Ice cube tray

Technical specifications

- Energy efficiency class **A+++**
- Climatic class SN-T
- Refrigerant R 600a
- Total Net Capacity, l 416
- Fridge volume, l 310
- Freezer volume, l 106
- Freezing Capacity 12 kg /24
- Annual energy consumption, kWh 276
- Net weight, kg 87,0
- Gross weight, kg 93,5
- **Dimensions** (H x B x T, cm)
- Unit dimensions 188,0 x 70,0 x 66,0
- Dimensions in packaging 190,5 x 66,0 x 72,0



Empire

REFRIGERATORS

BUILT-IN COMBINATION

Grand CHEF



EKK 60174



Design

- Product line GRAND CHEF
- Fully integrated refrigerator
- Built-in fridge freezer

Control

- Electronic full sensor control with programmer **Intelligent System**
- Multifunction LED-display
- Child safety lock

Comfort

- **No-frost**
- **Garden Box**
- Height-adjustable shelves made of high-quality safety glass **FREEZE BOX**
- **Super Frost**
- **Pizza Box**
- Audible beeps
- Holiday mode
- **LED** illumination
- Reversible door (L/R)
- Low noise
- Storage temperature up to -22°C , deep freezing
- Temperature increase alarm

Equipment

- Fridge shelves 4
- Vegetable / fruit crispers
- Bottle rack
- Egg tray
- Ice cube tray

Technical specifications

- Energy efficiency class **A+**
- Climatic class SN-T
- Refrigerant R 600a
- Total Net Capacity, l 241
- Fridge volume, l 182
- Freezer volume, l 59
- Freezing Capacity 3,5 kg /24 h
- Annual energy consumption 283 kW/h
- Net weight, kg 87,0
- Gross weight, kg 93,5

Dimensions (H x B x T, cm)

- Unit dimensions 177,6 x 54,0 x 54,5
- Niche dimensions 177,6 x 56,0 x 58,0
- Dimensions in packaging 184,5x58,0x58,5

Grand CHEF

REFRIGERATORS

SIDE-BY-SIDE COMBINATION

Avantgarde^{PLUS}



KS 90200 G



Design

- Product line *Avantgarde^{PLUS}*
- Gray glass

Control

- Electronic control **Logic control**
- Electronic full sensor control with programmer **Full Touch**
- Multifunction **LED**-display
- Child safety lock

Comfort

- **No-frost**
- **LED** illumination with **Day Light** System
- **Inverter**-compressor
- Low noise
- Storage temperature up to $-22\text{ }^{\circ}\text{C}$, deep freezing
- Temperature increase alarm
- Holiday mode

Equipment

- Racks / shelves 10 / 10
- Vegetable / fruit crispers
- Egg tray
- Ice cube maker

Technical specifications

- Energy efficiency class **A+**
- Climatic class **SN-T**
- Refrigerant R 600a
- Total Net Capacity, l 576
- Fridge volume, l 376
- Freezer volume, l 200
- Freezing Capacity 12 kg /24 h
- Annual energy consumption, kWh 467
- Net weight, kg 125,0
- Gross weight, kg 138,0

Dimensions (H x W x D, cm)

- Unit dimensions 180,2 x 91,5 x 71,7
- Dimensions in packaging 191,0 x 98,0 x 76,0

Avantgarde^{PLUS}

REFRIGERATORS

WINE COOLERS

ART DÉCO

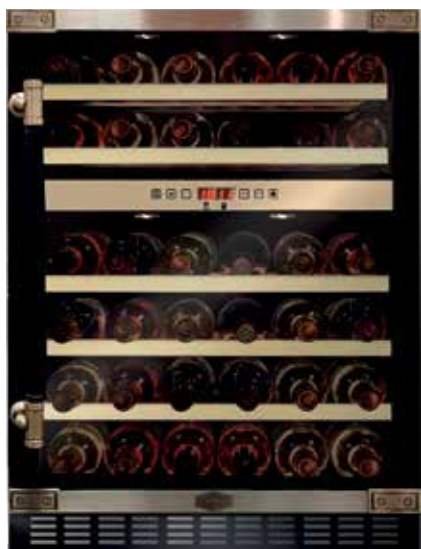

K 64750 AD

Design

- Product line **ART DÉCO**
- Anthracite colored
- Door handle and metal fittings **Antique Gold**
- Art Déco - leather covered handle's rod, metal parts **Antique Gold** with convex coat of arms

Control

- Electronic full sensor Dual-Zone control with **LED** display

Comfort

- Red wine / white wine cooler combination
- 46 bottles capacity
- 5 pull-out wooden shelves
- Circulation fan cooling
- UV-resistant **2 glasses** door
- Low noise
- Storage temperature up to 5 °C
- Reversible door

Technical specifications

- Energy efficiency class **A**
- Climatic class **N-SN-ST**
- Refrigerant **R 600a**
- Total Net Capacity, l **145**
- Annual energy consumption, kWh **146**
- Net weight, kg **43,0**
- Gross weight, kg **46,5**

Dimensions (H × W × D, cm)

- Unit dimensions **82,0 × 59,5 × 57,0**
- Dimensions in packaging **88,0 × 66,0 × 62,5**

**with 2
climate
zones**

**Red and
white wine**



K 64800 AD

Design

- Product line **ART DÉCO**
- Anthracite colored
- Door handle and metal fittings **Antique Gold**
- Art Déco - leather covered handle's rod, metal parts **Antique Gold** with convex coat of arms

Control

- Electronic full sensor Dual-Zone control with **LED** display

Comfort

- 40 bottles capacity
- 5 pull-out wooden shelves
- 3 height-adjustable chrome shelves
- Circulation fan cooling
- UV-resistant **2 glasses** door
- Low noise
- Storage temperature up to 5 °C

Technical specifications

- Energy efficiency class **B**
- Climatic class **N-SN-ST**
- Refrigerant **R 600a**
- Total Net Capacity, l **116**
- Annual energy consumption, kWh **197**
- Net weight, kg **43,3**
- Gross weight, kg **47,0**

Dimensions (H × B × T, cm)

- Unit dimensions **82,0 × 59,5 × 57,0**
- Dimensions in packaging **88,0 × 66,0 × 62,5**

**with 2
climate
zones**

Wine and beer



ART DÉCO





Dishwashers

DISHWASHERS

Fully automatic control

Thanks to the electronic programmer **Logic Control** all stages of operation is fully automatic. You simply need to choose one of the washing programs.

Sensor operation

With the sensor operation **Touch Control** you always have everything under control. It is very simple and intuitive operation



LCD displays

Many models of dishwashers equipped with bright, informative and multilingual **LCD**-displays. Display shows information about the program, countdown time and so on. The information is multilingual.

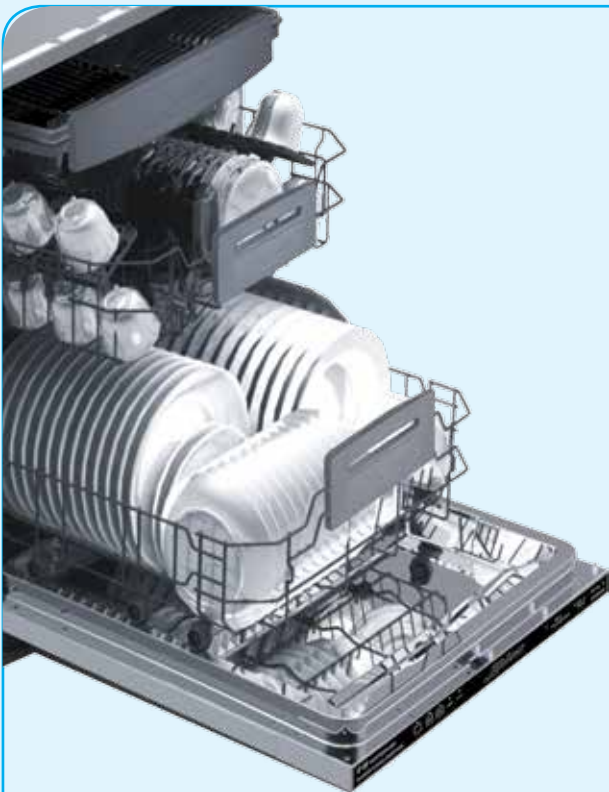

So big your dishwasher can be

Thanks to the new structure **XL** of our new model range the baskets and the interior become more space.

The machines with 45 cm width take not so much place in your kitchen and in same time have a wide capacity. You can place up to 10 complete sets of dishes in dishwasher.

In Dishwasher with 60 cm width you can place up to 14 complete sets of dishes.

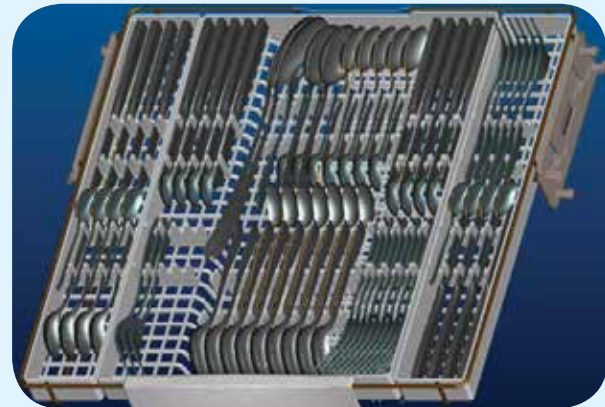

Removable cutlery drawer **Komfort-Plus**

The dishwasher is equipped with a removable cutlery drawer **Komfort-Plus** for cutlery, which prevents the contact of the cutlery and better flushing guaranteed. After the rinse, you can remove the cutlery rack and prepare them easily and effortlessly for unloading.

DISHWASHERS



The framework for the champagne glass

The folding frames have a special shape that offers optimal placement of champagne glass on the upper rack.



Wave spray arms

To optimize the rinsing quality special holes were designed for spraying. The holes are made under different angles, so each edge of the dishes will be fully washed and cleaned. The water currents do not interfere with each other there. The dishes will be perfectly clean and free of stains. Used for spraying multiple layers ensure optimal and economical washing.

Stainless steel heating elements and interior tank

Stainless steel interior tank ensures a long life of your device



The additional third shelf Teleskop

The new range of dishwashers is equipped with the additional third upper rack for the cutlery **Komfort-XL**, which significantly increases the capacity of the dishwasher. Special surface of third shelf prevents cutlery contacts and follows to better washing.



Special framework for the cups and glasses

The upper basket is equipped with openable framework, allowing you to place the cups, glasses and the high cup optimally on two levels.



The spacious vertically adjustable upper basket

The upper basket can be adjusted at any height, so that the inner space can be used rationally.

DISHWASHERS

Interior

The interior's design of dishwashers *Kaiser* and dish racks provides maximum space for together washing of various kinds of dishes.



Detergent dispenser

Upgraded triple detergent dispenser minimizes the detergent and electricity consumption. The design of dispenser offers you a possibility to use all common detergents such as powders, tablets or liquids.



Door

The door of the dishwasher Kaiser holds under any angle in the range from 0 to 90 degrees. Simply open the door and leave it open at the desired angle.

Extras inside the machine

Such extras as: Vertically adjustable upper basket, large cutlery rack **Komfort-XL**, especially comfortable original handles *Kaiser* will make you much pleasure in setting up and unloading the machine.

All baskets and cutlery racks are equipped with the system **Teleskop**.

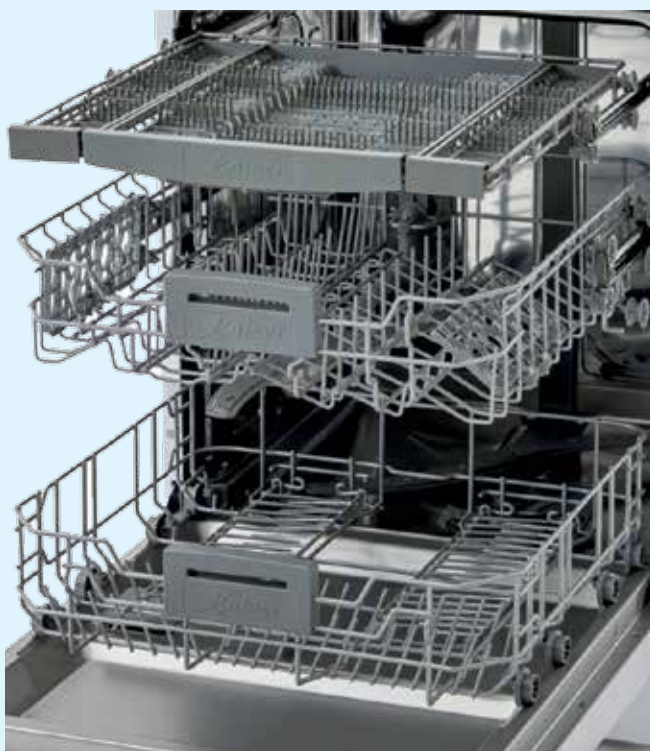

Aqua Stop function

All dishwashers *Kaiser* equipped with Aqua-Stop. The electronic system protects against the water leakage. Water supply will stop immediately.



AQUA STOP

Low noise operation

Dishwashers *Kaiser* are very quiet thanks to special technology of sound insulation and the latest trends in engine development. Nobody is disturbed by ambient noise of the machine.

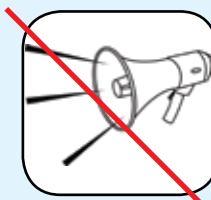

A++AA

Low power and water consumptionh

Extremely low power and water consumption of dishwashers *Kaiser* with the energy classes up to **A++AA** are guaranteed by the latest developments in engine technology and the introduction of recent trends in dishwashing.



Auto program

Auto program offers you the service of future: dishwasher can automatically determine from the wastewater contamination during flushing if the dishes must be washed or it is clean.



Programm Glass für delikates Geschirr

This program gives you the opportunity to wash fine dishes, glass, porcelain with very gently rinse, to protect it from damage.



Light

Brilliant **LED** illuminate every single corner of interior



The programmers of integrated models

allow you to select different languages to make use of the dishwasher (German, English, Russian, etc.) easy.

Programs and Functions

- Mode **3 in 1** - optimum results with washing tablets
- Program for crystal delicious dishes
- Start delay
- Half load



FULLY INTEGRATED

INCREASED VOLUME CAPACITY - XL 60CM



S 60 I 84 XL

Logic control Full touch 8 Programs  

Design

- Product line **XL 600^{PLUS}**
- Fully integrated

Control

- Electronic control **Logic control**
- Electronic full sensor control with programmer **Full Touch**
- **LED** function display with indicator

Comfort

- Multilingual display
- 8 main programs
- Program **Auto**
- Special function **3 in 1**
- Half loading
- Rinse aid refill indicator
- Salt refill indicator
- Delay start
- Capacity – 14 standard place settings
- Internal **LED** light

Equipment

- Stainless steel interior
- Vertically adjustable top basket
- Protection against water leakage
- **Aqua-Stop**
- Water softener
- **Komfort-XL** - third basket with **Teleskop** system
- Hot water connecting

Technical specifications

- Energy efficiency / Washing efficiency / Drying efficiency **A++ / A / A**
- Duration of Normal program 180 min / 55 °C
- Water consumption 11 l /cycle
- Energy consumption 0,93 kW /cycle
- Total power, kW 1,76
- Net weight, kg 44,0
- Gross weight, kg 51,0

Dimensions H x W x D, (cm)

- Unit dimensions 81,5 x 59,8 x 55,0
- Niche dimensions 82,0 x 60,0 x 58,0
- Dimensions in packaging 88,9 x 64,0 x 64,5



S 60 I 83 XL

Full touch Logic control 8 Programs 

Design

- Product line **XL 600^{PLUS}**
- Fully integrated

Control

- Electronic control **Logic control**
- Electronic full sensor control with programmer **Full Touch**
- **LED** function display with indicator

Comfort

- Multilingual display
- 8 main programs
- Program **Auto**
- Special function **3 in 1**
- Half loading
- Rinse aid refill indicator
- Salt refill indicator
- Delay start
- Capacity – 14 standard place settings

Equipment

- Stainless steel interior
- Vertically adjustable top basket
- Protection against water leakage
- **Aqua-Stop**
- Water softener
- **Komfort-XL** - third basket with **Teleskop** system
- Hot water connecting

Technical specifications

- Energieeffizienz/ Reinigungswirkung/ Trocknungswirkung **A+ / A / A**
- Duration of Normal program 160 min / 55° C
- Water consumption 12,5 l /cycle
- Energy consumption 1,04 kW /cycle
- Total power, kW 1,76
- Net weight, kg 44,0
- Gross weight, kg 51,0

Dimensions H x W x D, (cm)

- Unit dimensions 81,5 x 59,8 x 55,0
- Niche dimensions 82,0 x 60,0 x 58,0
- Dimensions in packaging 88,9 x 64,0 x 64,5



S 60 I 60 XL

Logic control Full touch 6 Programs 

Design

- Product line **XL 600^{PLUS}**
- Fully integrated

Control

- Electronic control **Logic control**
- Electronic full sensor control with programmer **Full Touch**
- **LED** function display with indicator

Comfort

- Multilingual display
- 6 main programs
- Special function **3 in 1**
- Half loading
- Rinse aid refill indicator
- Salt refill indicator
- Delay start
- Capacity – 14 standard place settings

Equipment

- Stainless steel interior
- Vertically adjustable top basket
- Protection against water leakage
- **Aqua-Stop**
- Water softener
- **Komfort-XL** - third basket with **Teleskop** system
- Hot water connecting

Technical specifications

- Energy efficiency / Washing efficiency / Drying efficiency **A+ / A / A**
- Duration of Normal program 160 min / 55° C
- Water consumption 12,5 l /cycle
- Energy consumption 1,02 kW /cycle
- Total power, kW 1,76
- Net weight, kg 44,0
- Gross weight, kg 51,0

Dimensions H x W x D, (cm)

- Unit dimensions 81,5 x 59,8 x 55,0
- Niche dimensions 82,0 x 60,0 x 58,0
- Dimensions in packaging 88,9 x 64,0 x 64,5

FULLY INTEGRATED

INCREASED VOLUME CAPACITY - XL 45 CM



S 45 I 84 XL

Full touch control **Logic control** **8 Programs**  

Design

- Product line **XL 450^{PLUS}**
- Fully integrated

Control

- Electronic control **Logic control**
- Electronic full sensor control with programmer **Full Touch**
- **LED** function display with indicator

Comfort

- Multilingual display
- 8 main programs
- Program **Auto**
- Special function **3 in 1**
- Half loading
- Rinse aid refill indicator
- Salt refill indicator
- Delay start
- Capacity – 10 standard place settings
- Internal **LED** light

Equipment

- Stainless steel interior
- Vertically adjustable top basket
- Protection against water leakage **Aqua-Stop**
- Water softener
- **Komfort-XL** - third basket with **Teleskop** system
- Hot water connecting

Technical specifications

- Energy efficiency / Washing efficiency / Drying efficiency **A+ / A / A**
- Duration of Normal program 155 min / 55 °C
- Water consumption 10 l /cycle
- Energy consumption 0,83 kW /cycle
- Total power, kW 1,76
- Net weight, kg 36,0
- Gross weight, kg 42,0

Dimensions H x W x D, (cm)

- Unit dimensions 81,5 x 44,8 x 55,0
- Niche dimensions 82,0 x 45,0 x 58,0
- Dimensions in packaging 88,9 x 49,5 x 64,5



S 45 I 83 XL

Full touch control **Logic control** **8 Programs** 

Design

- Product line **XL 450^{PLUS}**
- Fully integrated

Control

- Electronic control **Logic control**
- Electronic full sensor control with programmer **Full Touch**
- **LED** function display with indicator

Comfort

- Multilingual display
- 8 main programs
- Program **Auto**
- Special function **3 in 1**
- Half loading
- Rinse aid refill indicator
- Salt refill indicator
- Delay start
- Capacity – 10 standard place settings

Equipment

- Stainless steel interior
- Vertically adjustable top basket
- Protection against water leakage **Aqua-Stop**
- Water softener
- **Komfort-XL** - third basket with **Teleskop** system
- Hot water connecting

Technical specifications

- Energy efficiency / Washing efficiency / Drying efficiency **A+ / A / A**
- Duration of Normal program 155 min / 55° C
- Water consumption 10 l /cycle
- Energy consumption 0,83 kW /cycle
- Total power, kW 1,76
- Net weight, kg 36,0
- Gross weight, kg 42,0

Dimensions H x W x D, (cm)

- Unit dimensions 81,5 x 44,8 x 55,0
- Niche dimensions 82,0 x 45,0 x 58,0
- Dimensions in packaging 88,9 x 49,5 x 64,5



S 45 I 60 XL

Full touch control **Logic control** **6 Programs** 

Design

- Product line **XL 450^{PLUS}**
- Fully integrated

Control

- Electronic control **Logic control**
- Electronic full sensor control with programmer **Full Touch**
- **LED** function display with indicator

Comfort

- Multilingual display
- 6 main programs
- Special function **3 in 1**
- Half loading
- Rinse aid refill indicator
- Salt refill indicator
- Delay start
- Capacity – 10 standard place settings

Equipment

- Stainless steel interior
- Vertically adjustable top basket
- Protection against water leakage **Aqua-Stop**
- Water softener
- **Komfort-XL** - third basket with **Teleskop** system
- Hot water connecting

Технические данные

- Energy efficiency / Washing efficiency / Drying efficiency **A+ / A / A**
- Duration of Normal program 155 / 55° C
- Water consumption 10 l /cycle
- Energy consumption 0,90 kW /cycle
- Total power, kW 1,76
- Net weight, kg 36,0
- Gross weight, kg 42,0

Dimensions H x W x D, (cm)

- Unit dimensions 81,5 x 44,8 x 55,0
- Niche dimensions 82,0 x 45,0 x 58,0
- Dimensions in packaging 88,9 x 49,5 x 64,5

BUILT-IN DISHWASHERS

Empire

BUILT-UNDER

INCREASED VOLUME CAPACITY - XL 60 CM



S 60 U 87 XL Em

PUSH 6 Programs  
Bronze

Anthracite coloured enamel

Design

- Product line **Empire**
- Built under
- Antique decor
- Door handle – solid metal **Bronze**

Control

- Electronic control **Logic control**
- **LED** function display with indicator
- Push buttons / **Bronze**



S 60 U 87 XL ElfEm

PUSH 6 Programs  
Bronze

Ivory coloured enamel

Comfort

- 6 main programs
- Program **Auto**
- Half loading
- Rinse aid refill indicator
- Salt refill indicator
- Delay start
- Capacity – 14 standard place settings

Equipment

- Stainless steel interior
- Vertically adjustable top basket
- Protection against water leakage
- **Aqua-Stop**
- Water softener
- **Komfort-XL** – third basket with **Teleskop** system
- Hot water connecting



S 60 U 87 XL RotEm

PUSH 6 Programs  
Bronze

Bordeaux coloured enamel

Technical specifications

- Energy efficiency / Washing efficiency / Drying efficiency **A++ / A / A**
- Duration of Normal program 175 min / 55 °C
- Water consumption 11 l /cycle
- Energy consumption 0,93 kW /cycle
- Total power, kW 1,76
- Net weight, kg 46,0
- Gross weight, kg 54,0

Dimensions (H × W × D, cm)

- Unit dimensions 84,5 × 59,8 × 64,0
- Niche dimensions 86,0 × 61,0 × 66,0
- Dimensions in packaging 88,4 × 63,0 × 69,5

Empire



FREE-STANDING DISHWASHERS

Avantgarde^{PLUS}

INCREASED VOLUME CAPACITY - XL 45 /60 CM

Built-in dishwashers also available as similar free-standing



S 6086 XL

S 6086 XL W

8 Programs Full touch Logic control INOX Anti touch 



S 6062 XL

S 6062 XL W

S 6062 XL S

6 Programs Full touch Logic control INOX Anti touch 

Same functions and features as model S 60 I 84 XL

Same functions and features as model S 60 I 60 XL



S 4586 XL

S 4586 XL W

8 Programs Full touch Logic control INOX Anti touch 



S 4562 XL

S 4562 XL W

S 4562 XL S

6 Programs Full touch Logic control INOX Anti touch 

Same functions and features as model S 45 I 84 XL

Same functions and features as model S 45 I 60 XL

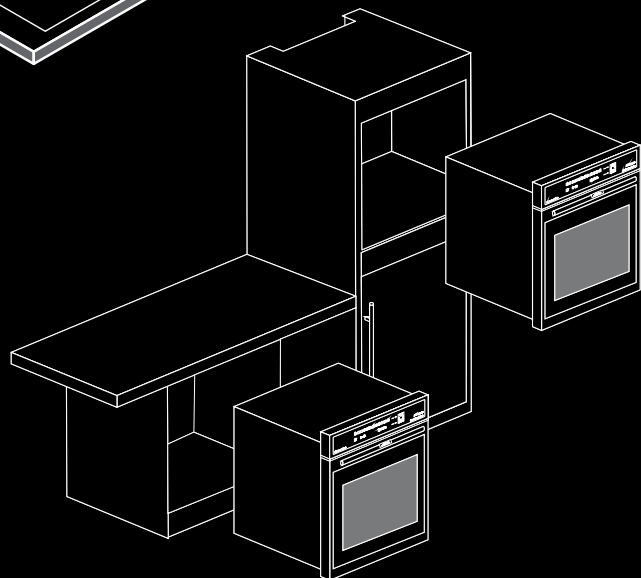
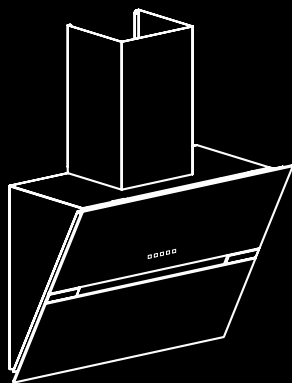
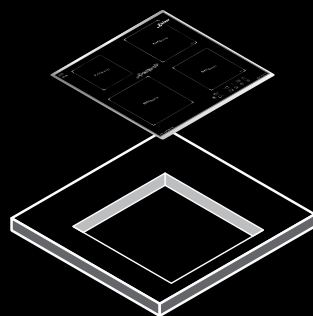
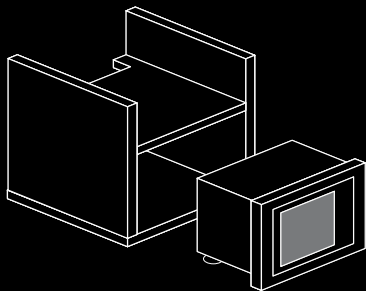
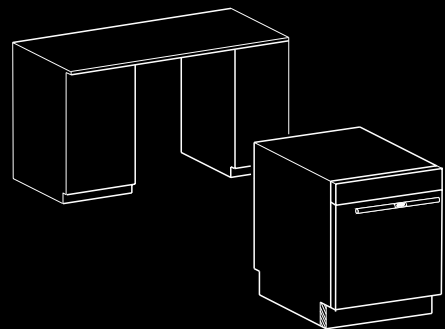
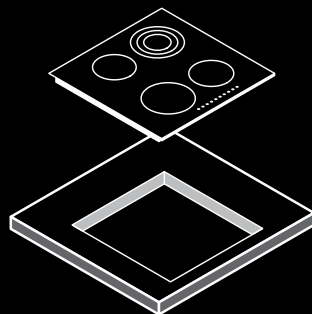
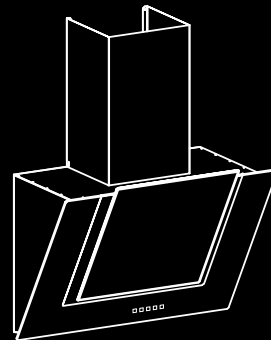
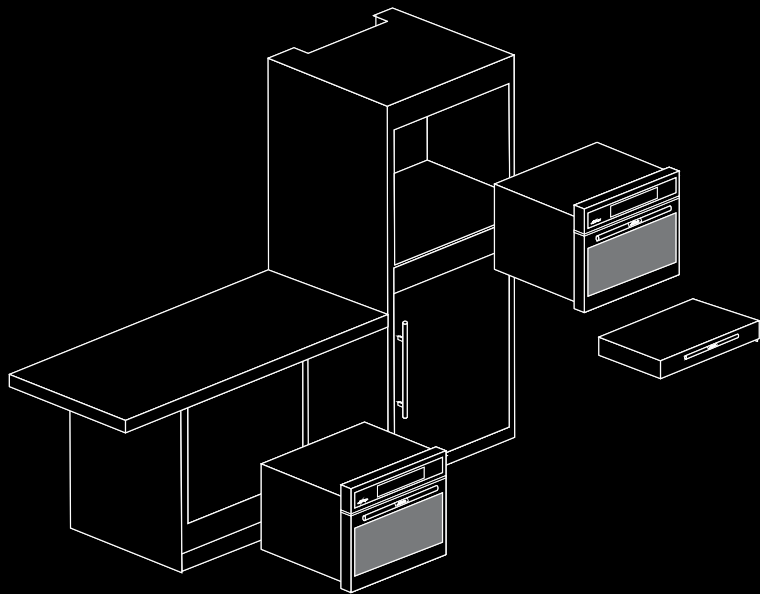

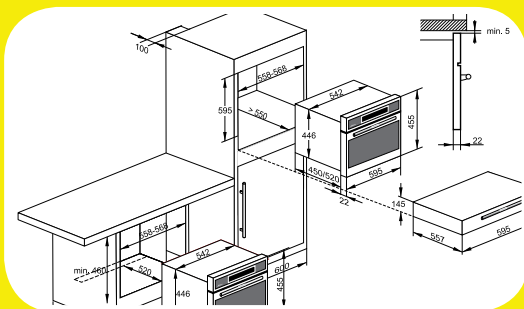

Installation diagrams

BUILT-IN APPLIANCES, MOUNTING DRAWINGS

HOBS

**KCT 34...
KCT 37...**

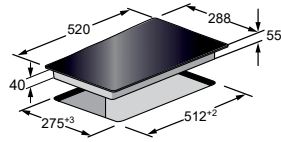

**KG 33...
KCG 33...**

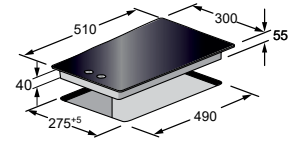

KCT 47...

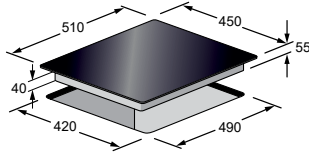

**KG 43...
KCG 43...**

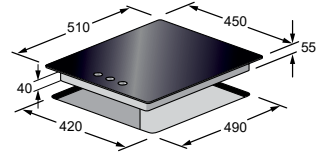

**KCT 61...
KCT 63...
KCT 64...
KCT 65...
KCT 67...
KCT 69...
KC 69...**

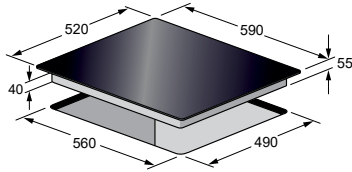

**KG 63...
KCG 63...**

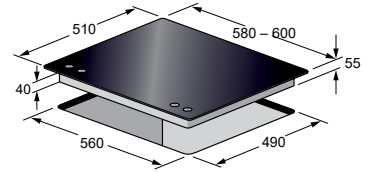

KCT 77...

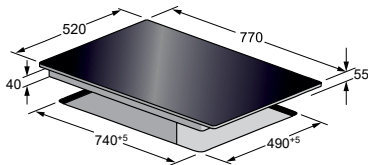

KCG 83...

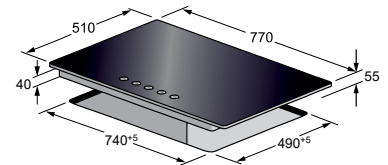

**KCT 95...
KCT 96...
KCT 97...**

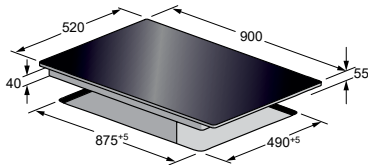

**KG 93...
KCG 93...**

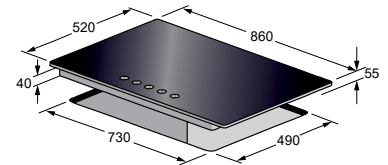

MICROWAVE OVENS

EM 25...

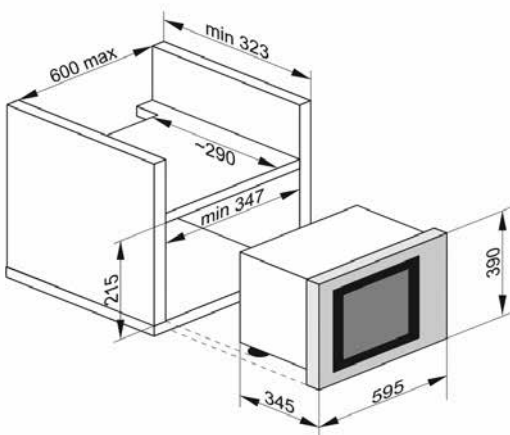

BUILT-IN APPLIANCES, MOUNTING DRAWINGS

COOKER HOODS

EA 543

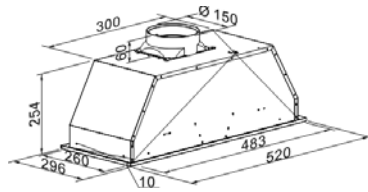

EA 743

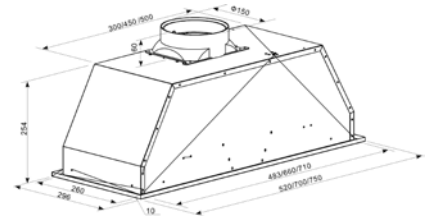

EA 644

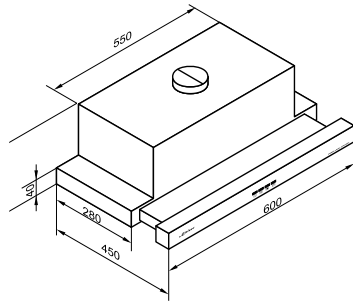

**AI 10...
AI 11...**

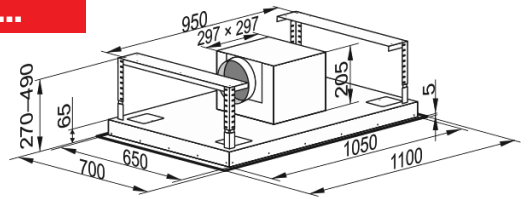

**EA 546
EA 745
EA 945
EA 946**

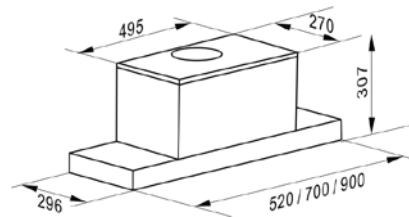

BUILT-IN DISHWASHERS

S 45...

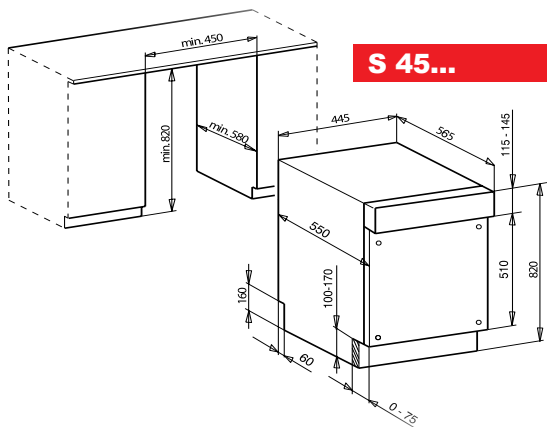

S 60...

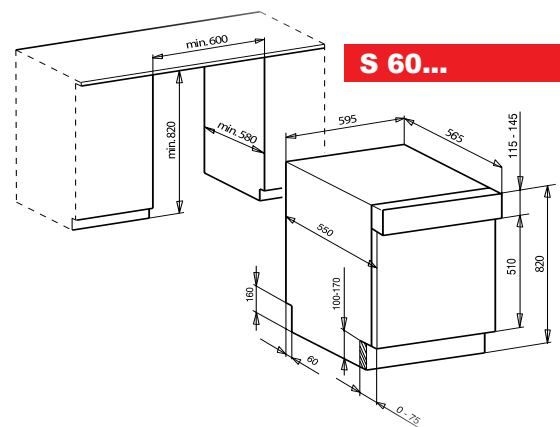

All presented models of the ovens, dishwashers, hobs and cooker hoods are perfectly mount into the furniture production in EU countries.

BUILT-IN APPLIANCES, MOUNTING DRAWINGS

OVENS

**EH 63...
EG 63...
EH 64...**

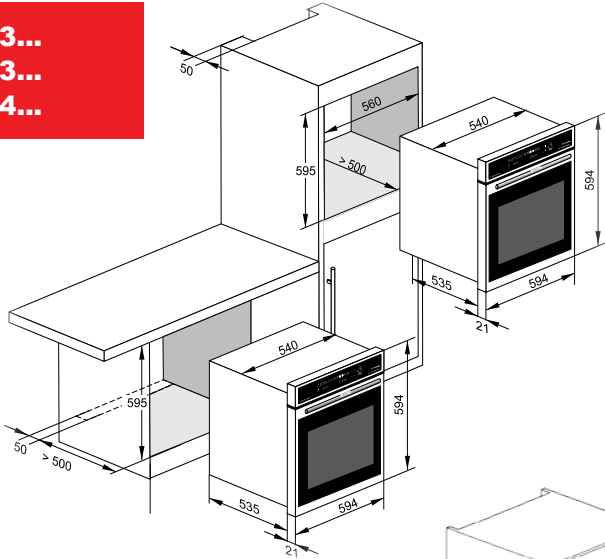

KOMPAKT 45

**EH 6314... mit
EH 6319...
EH 6312...
EH 6318...**

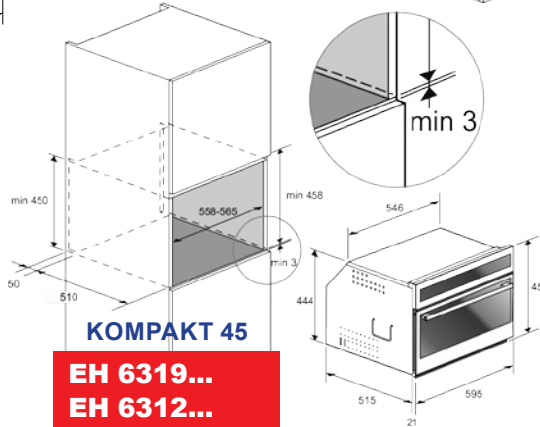
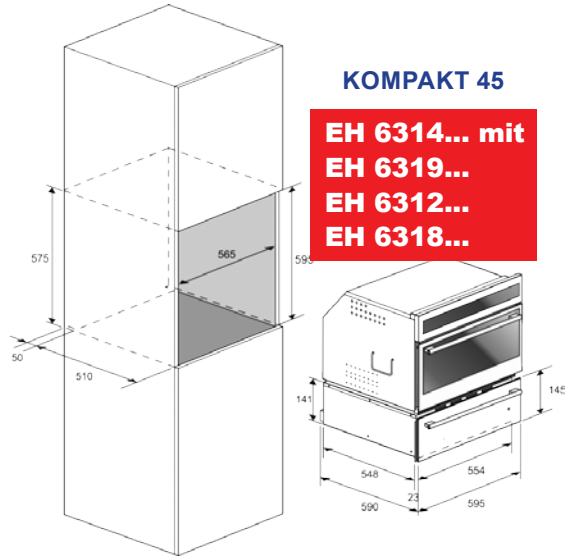

KOMPAKT 45

**EH 6319...
EH 6312...
EH 6318...**

REFRIGERATORS

EKK 60...

All dimensions in mm

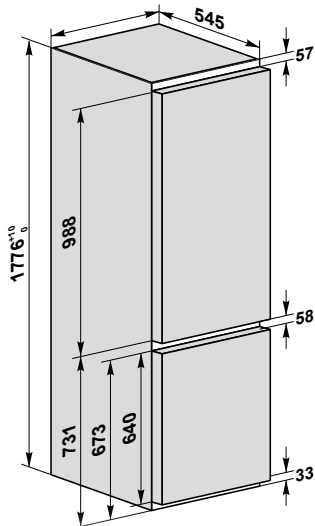

All dimensions in mm

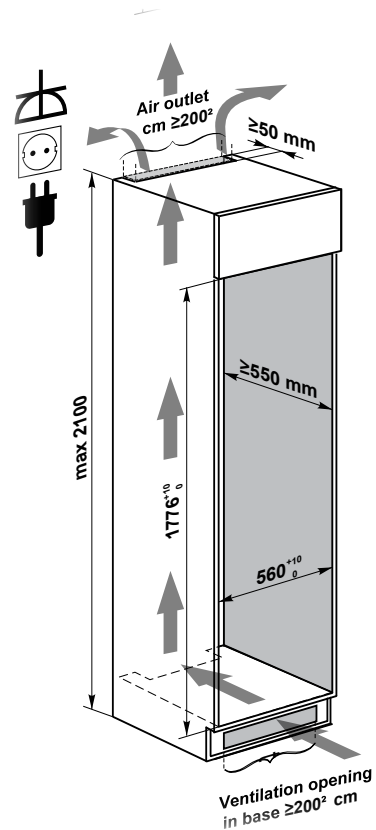
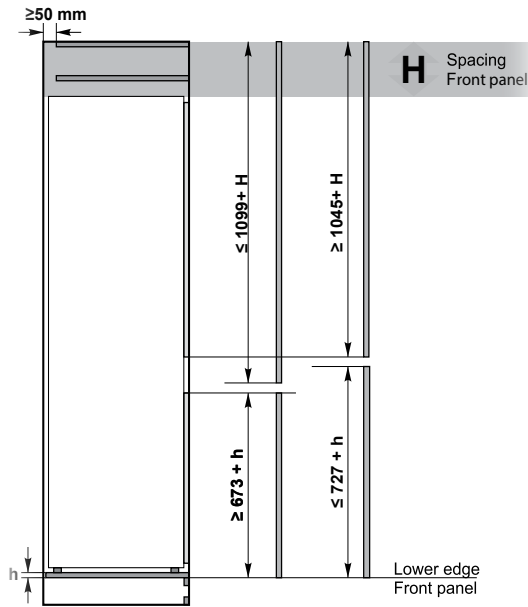

The specified furniture dimensions apply to a 4 mm door joint

DESCRIPTION OF THE OVENS' FUNCTIONS

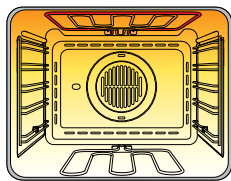

Top heat 1000 W

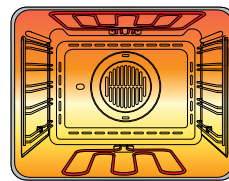

Double grill and bottom heat
Double grill: 2200 W;
Bottom heat: 1100 W

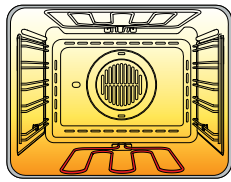

Bottom heat 1100 W

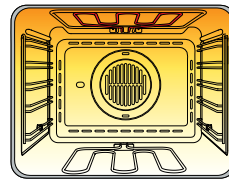

Electric grill 1200 W

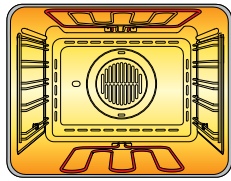

Top and bottom heat
Top heat: 1000 W;
Bottom heat: 1100 W

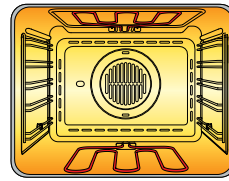

Electric grill 1200 W
and bottom heat 1100 W

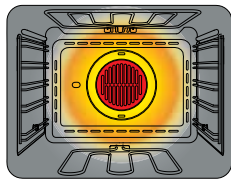

Hot air system 2300 W

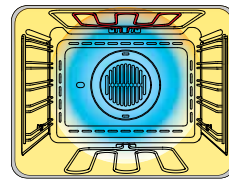

Electric grill
and hot air system 1200 W

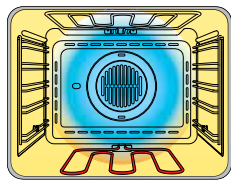

Hot air system and bottom heat
Bottom heat: 1100 W

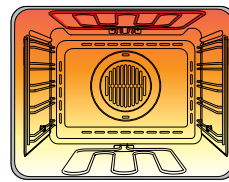

Double grill 2200 W

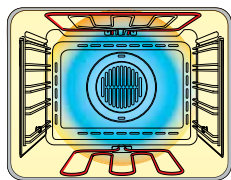

Top-/bottom heat and hot
air system
Top heat: 1000 W;
Bottom heat: 1100 W

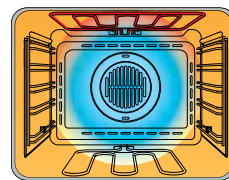

Double grill
and hot air system 2200 W

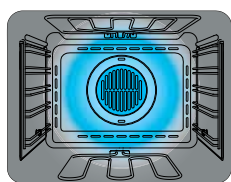

Cold air system (defrosting)

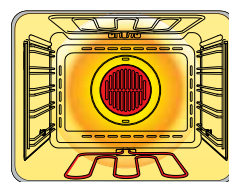

Hot air system 2300 W
and bottom heat 1100 W

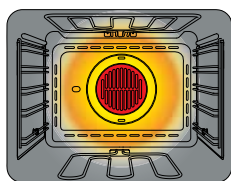

Thermodefrosting

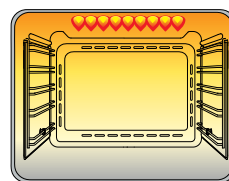

Top gas burner with system
Gas Control 2200 W

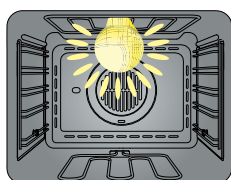

Lighting

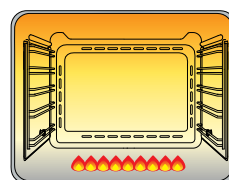

Bottom gas burner system
Gas Control 2500 W

Kaiser



Power in action

Kaiser

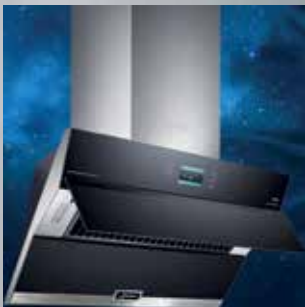

Kaiser

OLAN-Haushaltgeräte
Eichborndamm 277
13437 Berlin
Germany
www.kaiser-olan.de



Die Firma übernimmt keine Haftung für Druckfehler und behält sich das Recht vor, Änderungen der Struktur und des Designs der einzelnen Geräte durchzuführen, die keine Auswirkungen auf die Qualität oder auf die Eigenschaften des jeweiligen Produktes haben.



www.kaiser-olan.de